



## Monitoring battery charging using Node-RED

Nur Vidia Laksmi B.<sup>1\*</sup>, Muhammad Syahril Mubarak<sup>2</sup>, Reza Rahmadian<sup>1</sup>, Mahendra Widyartono<sup>1</sup>,  
Ayusta Lukita Wardhani<sup>1</sup>, Aditya Candra Hermawan<sup>1</sup>, Muhammad Abdus Salam<sup>1</sup>,

<sup>1</sup>Department of Electrical Engineering, Faculty of Vocational, Universitas Negeri Surabaya, Surabaya, Indonesia

<sup>2</sup>Department of Engineering, Faculty of Advanced of Technology and Multidiscipline, Universitas Airlangga, Surabaya, Indonesia

### Article Info

#### Article history:

Received Jul 26, 2024

Revised Aug 9, 2024

Accepted Aug 19, 2024

#### Keywords:

Battery

Charger

Node-RED

ESP32

Internet of things

### ABSTRACT

The need for a smart grid has been spurred by the growth of distributed generation, the aging of the current grid infrastructure, and the desire to alter networks. The development and enhancement of smart grid technology is significantly facilitated by the Internet of Things (IoT) technology. Batteries play a crucial role in the energy storage of electrical systems, including smart microgrids and electric vehicles. To enhance performance and prolong battery life, a Battery Monitoring System (BMS) is required to manage the energy storage process dynamics within the battery. Battery life prediction contributes to the consistent and efficient operation of battery-powered devices. This research presents battery charging monitoring using Nodered. Apart from that, the battery charging feature uses a cut-off concept. The cut off on the battery is to prevent the battery from over-discharging which can damage the battery and shorten its lifespan. This research carried out validation using 3 case studies on battery charging. Validation of measurements uses a comparison between the INA 219 sensor and a multimeter. From experiments, current testing from 3 case studies, it was found that the average difference in current sensor error was 0.19%.

This is an open access article under the [CC BY-SA](https://creativecommons.org/licenses/by-sa/4.0/) license.



## 1. INTRODUCTION

The need for electrical energy is currently a basic requirement that is needed in everyday life, whether used for household, industrial or automotive needs. The higher the population, the greater the need for electrical energy to meet electricity needs continues to increase, but the availability is not yet sufficient [1]-[2]. Rechargeable batteries are becoming increasingly common among various energy storage devices due to advancements in the area. An energy storage system (ESS) is necessary for renewable energy sources to ensure a steady and uninterrupted supply to the consumer [3]. A battery's safety, dependability, efficiency, and long-term functioning are ensured by the Battery Management System (BMS), a crucial component of any battery-powered system. Even if a battery pack's cooling system is well-designed, the temperature of each cell varies [4].

Managing the deterioration of battery health, which is mostly exhibited by capacity loss, is a major task in battery management. The battery's maximum capacity continuously decreases as the number of charge/discharge cycles increases. To creating efficient battery management plans and scheduling maintenance tasks, it is essential to accurately assess the maximum battery capacity [5]. The battery cut-off concept refers to the principle of managing battery power to extend its service life and ensure optimal performance. When we use devices that use batteries, such as cell phones or laptops, the power management system is often equipped with a battery cut off feature. The basic principle of battery cut-off is to prevent the battery from over-discharging which can damage the battery and shorten its lifespan [6]-[7].

The term "Internet of Things" (IoT) describes how commonplace objects are connected via networks. This kind of wireless device linkage is self-organizing and designed to connect commonplace objects. Through

\*Email: nurvidialaksmi@unesa.ac.id

interfaces with sensors, two-dimensional codes on objects, and electronic IDs, it is connected to wireless networks. IoT technology facilitates machine-to-machine or human-machine communication. IoT is primarily defined by three characteristics: sufficient size, intelligence, and internet connectivity [8]. Data collection, bilateral communication, handling, and reaction control are the four components of the Internet of Things. A visual programming environment called Node-RED was created expressly to link online services, IoT devices, and other dispersed systems together into a clear data stream. By assembling "nodes," or building blocks, users can construct intricate visual workflows [9].

Several studies regarding battery monitoring based IoT have been presented by several researchers. Isaías Gonzalez et al presented a monitoring system based on IoT technology for batteries integrated in a Battery Powered Hydrogen Microgrid (BHMG). The data provided by is transmitted to an internal IoT server and displayed through a user interface developed using Grafana software [10]. Xiaoping Wang et al presented a battery monitoring system based on Narrow Band Internet of Things (NB-IoT). The system is designed with STM32F103 as the main control chip, and the BQ76930 chip collects relevant information such as voltage, current and temperature. Battery information is sent to the Alibaba Cloud server via the NB-IoT module, and state of charge (SOC) estimation and information storage are carried out on the server [11]. Zena Ez Dallalbashi et al discuss the development of a photovoltaic (PV) system battery performance monitoring unit. This will be done using an Arduino and a long-range wide area network (LoRaWAN) as a control and monitoring system [12].

The application of Node-red as a framework for several monitoring applications has been implemented by several researchers. The application of Node-red as a framework for several monitoring applications has been implemented by several researchers. Nurazamiroz Bin Kamarozaman et al present a portable patient monitoring system based on the Internet of Things (IoT) which can be installed on remote patients without requiring the patient to be constrained by cables and remain in bed throughout. day. The MQTT server protocol is used to send data to Node-Red and ThingSpeak for monitoring [13]. Paul Macheso et al present a smart home design using Message Queuing Telemetry Transport (MQTT) and Node-RED. Smart home solution design using MQTT mosquito broker on raspberry Pi 3B+, single board computer development board [14]. Luis González et al explain the development of a water source monitoring system in the Tres Lagunas Andean highland wetland ecosystem (Ecuador), using LoRa technology. The system design mainly involves an ATmega1284p micro-controller, LoRa transceiver, and physicochemical sensors. The data collected from the research location is sent to the server and then forwarded to the Node-RED platform using the MQTT protocol [15]. Although IoT-based research has been widely presented. research on monitoring and Node-red still has a lot of space that can be explored. This research has contributions, namely:

1. This research presents battery charging monitoring using Node-red
2. This research uses a cut-off method for battery charging

This article has the following structure: the 2nd one presents the applied methods and a complete study of IoT, Node-red, NodeMCU ESP 32 and INA 219 Sensor. The 3rd part reviews the results and performance analysis. The final section is to present the conclusions obtained.

## 2. METHOD (10 PT)

### 2.1. Internet of Things (IoT)

Internet of Things (IoT) refers to the concept where physical objects, devices, vehicles, and even people are equipped with sensor technology, software, and internet connections that enable them to communicate with each other and exchange data automatically [16]–[18]. The goal is to create a connected environment where devices can interact, share information, and perform actions without human intervention. Objects in the IoT ecosystem are equipped with various sensors (such as temperature sensors, motion sensors, humidity sensors) and communication devices (such as microcontrollers, wireless modems) that enable them to collect data and communicate with other devices and IoT platforms. Communication between objects in IoT and the IoT platform or infrastructure usually uses an internet connection. This may include Wi-Fi connections, cellular networks (3G/4G/5G), Bluetooth, or other wireless technologies. Data collected by IoT devices is sent to an IoT platform, where it is processed, analyzed and used to make decisions. These platforms often include cloud computing infrastructure, artificial intelligence algorithms, and analytical software. Data collected by IoT devices is used for a variety of purposes, including automated monitoring and control, predictive analysis, process optimization, energy savings, predictive maintenance, and more.

The essence of the IoT concept is connecting physical objects to the internet to collect data, analyze that data, and take appropriate action based on the resulting insights. This makes it possible to create connected and intelligent environments that can monitor, control, and respond automatically to environmental conditions and user needs [19]. The Internet of Things (IoT) offers several significant advantages in various areas of life and industry. IoT enables real-time data collection from various devices and sensors. This enables accurate and

timely monitoring of condition, performance, and environment. Examples include real-time patient health monitoring, city infrastructure monitoring, or production monitoring in factories. With IoT, processes can be automated based on the data collected. This reduces human involvement, increases efficiency, and reduces human error. An example of an application is a smart home system that automates temperature, lighting, and home security settings. IoT can be used to optimize energy usage and reduce unnecessary energy consumption. Examples include energy management systems in buildings that regulate lighting and air conditioning based on environmental conditions and human presence [20]. Figure 1 is an illustration of the characteristics of IoT

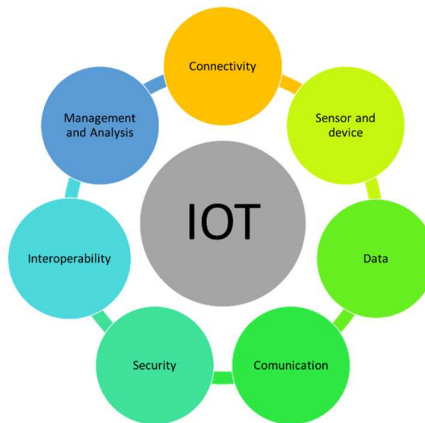

Figure 1. IoT characteristics

## 2.2. Node-Red

Node-RED is a visual programming platform designed to connect IoT devices, web services, and other distributed systems in an easy-to-understand data stream. It allows users to create visual-based workflows using blocks called "nodes" and connect them to form complex application logic [1]. Node-RED provides a web-based user interface that allows users to create and edit workflows using drag-and-drops [2]. It allows users to quickly build and change application logic without special knowledge of programming. Node-RED has a wide variety of nodes that cover functions such as input (e.g., IoT sensors, RSS feeds), output (e.g., databases, web services), data transformation, flow control, and more. Users can easily add new nodes from the available libraries or create their own custom nodes. Node-RED can connect to various devices and services via dedicated nodes. This includes integration with IoT platforms such as MQTT, HTTP, and CoAP, as well as cloud services such as AWS, Microsoft Azure, and Google Cloud [3]. Users can orchestrate workflows using connected nodes by defining the setup logic, conditions, data transformations, and actions required to run their applications. Additionally, Node-RED has an active community that continues to develop new nodes, tutorials, and solutions for various use cases. This makes it a flexible and widely extensible platform [4]

## 2.3. NodeMCU ESP32

NodeMCU ESP32 is a variant of NodeMCU which uses the ESP32 chip from Espressif Systems as its base. NodeMCU itself is an open-source development platform that uses the Lua programming language and is specifically designed for developing IoT applications. By using ESP32 as its base, NodeMCU ESP32 has similar features to the standalone ESP32, but with the added ability to use Lua as a programming language for IoT application development. This makes it a popular choice for developers who want to leverage the advantages of ESP32 in IoT applications while still using a simpler, easier-to-understand programming language [5].

## 2.4. Battery Charging

The concept of the tool created in this research is that users can monitor applications based on the Node-RED platform. When charging. The cable is connected to a tool according to the battery poles, then the INA219 sensor will read the voltage on the battery. When the battery voltage is less than 12.5 V, the relay will turn on until the voltage reaches 12.5 V. When the voltage value is 12.5 V, the relay will automatically trip and send a notification to the application. An illustration of a battery charging tool can be seen in Figure 2. Details of the wiring for the battery charging device can be seen in Figure 3. This prototype uses the INA219 sensor as a component to detect current and voltage. The INA219 sensor is a very vital component. This component functions as a voltage and current reading, and also functions as a cut-off setting when charging is full. To calibrate this sensor, we can do this by:

1. Enter the script on the Arduino by first downloading the library from the sensor.
2. Connect each pin of the INA219 sensor according to the wiring in Figure 3
3. Next, upload the example script from the library that was downloaded previously, then try checking it via the serial monitor in the Arduino application.

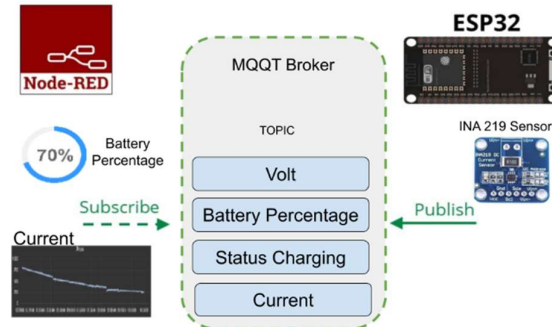

Figure 2. Illustration of the proposed method

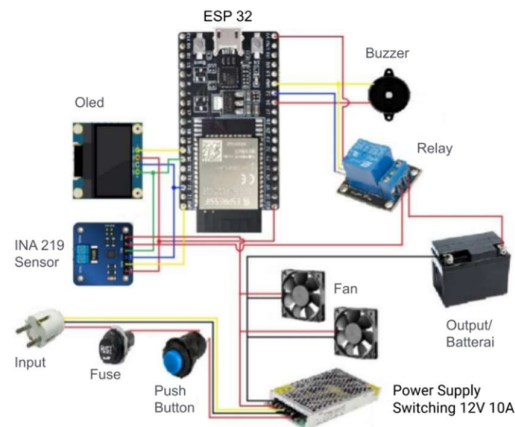

Figure 3. Illustration of the Battery Charging Wiring Design

After calibrating the INA219 sensor, the next step is testing the sensor to disconnect the battery charger using Node-RED, as follows:

1. Upload the program that has been created on the Arduino software to the ESP 32
2. Connect the pins of each component to the esp32
3. Open the Node-RED dashboard application first on the local host (<http://127.0.0.1:1880>) to adjust the flow according to your needs.
4. Adjust the function node in the form of a server and also a topic according to the script that has been created (in Figure 4)
5. After connecting the flows between nodes, the next step is to set the layout on the Node-Red dashboard menu (in Figure 5)
6. Application display on the local host (In Figure 6)

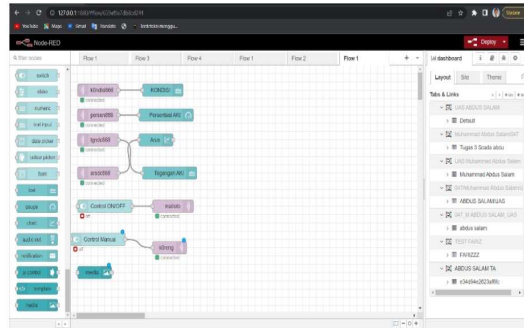

Figure 4. Flow on the Node-RED Dashboard

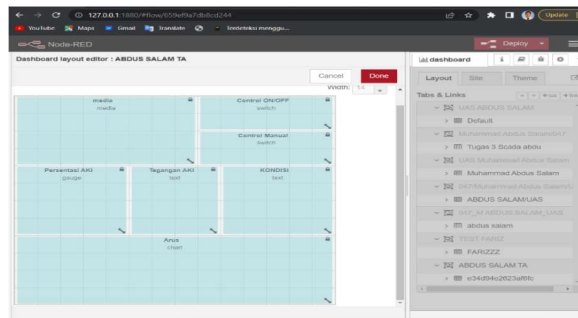

Figure 5. Monitoring Layout Settings on Node-RED

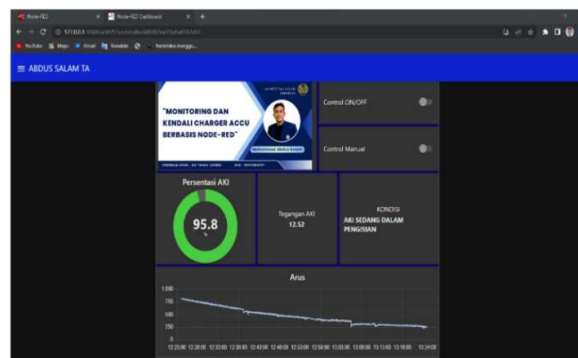

Figure 6. Monitoring Layout Settings on Node-RED

**3. RESULTS AND DISCUSSION**

This research validates and verifies the tool using 3 different case studies. Case study 1 uses a 12 V 3.5 Ah battery, case study 2 uses a battery with specifications 12 V 4.5 Ah and case study 3 charging the battery simultaneously with the method parallel battery with battery specifications 12 V 3.5 Ah and 12 V 4.5Ah. Several things will be tested through filling above is the accuracy of the current and voltage sensors using the INA219 sensor. Several things were tested, namely the accuracy of the current and voltage sensors using the INA219 sensor. Testing the cut-off setting of the battery charger aims to determine whether the relay trips automatically when charging reaches 12.55 V. To find out the average current entering the battery when charging, we can calculate it using the equation as follows

$$X = \frac{\Delta I}{\Delta S} \tag{1}$$

where  $X$  is average current,  $\Delta I$  is total current.  $\Delta S$  is sample data. From the results of case study 1 with a charging time of 90 minutes and data collection every 10 minutes. The average result of the current entering

the battery on the multimeter was 0.36 A and the average current on the INA219 sensor was 0.44 A. The average error result of the current sensor using the INA219 sensor was 0.21%. Complete data for case study 1 can be seen in Table 1. Meanwhile, a comparison of voltage measurements between the multimeter and the INA 219 sensor showed an error of 0.06%. Complete comparative data on voltage measurements between the multimeter and the INA 219 sensor can be seen in Table 2. Figure 8 is a comparison graph of voltage measurements between the multimeter and the INA 219 sensor. From Table 1, the graph illustrates the comparison of current measurements from the multimeter and the INA219 sensor in Figure 7. The results shown in the graph are changes in current data obtained 9 times. Data collection takes every 10 minutes.

Table 1. Comparison results of current measurements between multimeter and the INA 219 sensor in case study 1

Time (minute)	Current (multimeter) (A)	Current (INA219 Sensor) (A)	Difference	Error (%)
10	0.69	0.87	0.18	26.08696
20	0.57	0.73	0.16	28.07018
30	0.5	0.53	0.03	6
40	0.38	0.48	0.1	26.31579
50	0.29	0.37	0.08	27.58621
60	0.24	0.28	0.04	16.66667
70	0.23	0.28	0.05	21.73913
80	0.19	0.23	0.04	21.05263
90	0.17	0.2	0.03	17.64706
Average	0.362222222	0.441111111	0.0788889	21.68969

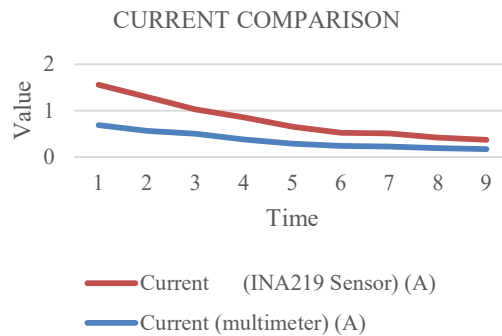

Figure 7. Comparison of current measurements using a multimeter and the INA 219 sensor in case study 1.

Table 2. Comparison results of volt measurements between multimeter and the INA 219 sensor in case study 1

Time (minute)	Volt (multimeter) (V)	Volt (INA219 Sensor) (V)	Difference	Error (%)
10	12.42	12.44	0.02	0.161030596
20	12.46	12.46	0	0
30	12.49	12.48	0.01	0.080064051
40	12.5	12.49	0.01	0.08
50	12.51	12.5	0.01	0.079936051
60	12.52	12.52	0	0

70	12.53	12.53	0	0
80	12.55	12.54	0.01	0.079681275
90	12.56	12.55	0.01	0.079617834
Average	12.5044444	12.5011	0.0077777	0.060088997

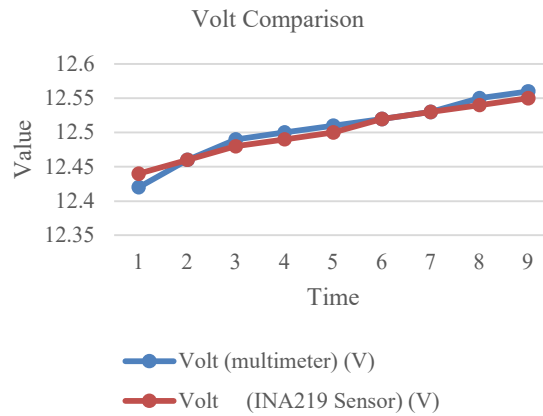

Figure 8. comparison of Volt measurements using a multimeter and the INA 219 sensor in case study 1.

Case study 2 is used to charge a battery with a 12 V 4.5 Ah specification. The current test results can be seen in Table 3 and Figure 9 which shows that the charging time was 140 minutes with an average current output on the multimeter results of 0.523 A and on the INA 219 sensor of 0.64 A. Meanwhile, in The results of table 4 and Figure 10 show a graph of changes in voltage during charging for 140 minutes between the multimeter and the INA 219 sensor and get a sensor error percentage of 0.08%.

Table 3. Comparison results of current measurements between multimeter and the INA 219 sensor in case study 2

Time (minute)	Current (multimeter) (A)	Current (INA219 Sensor) (A)	Difference	Error
10	1.16	1.54	0.38	32.75862
20	1.09	1.37	0.28	25.68807
30	0.86	1.1	0.24	27.90698
40	0.7	1.03	0.33	47.14286
50	0.64	0.71	0.07	10.9375
60	0.44	0.53	0.09	20.45455
70	0.44	0.5	0.06	13.63636
80	0.37	0.46	0.09	24.32432
90	0.38	0.38	0	0
100	0.31	0.33	0.02	6.451613
110	0.26	0.29	0.03	11.53846
120	0.28	0.29	0.01	3.571429
130	0.25	0.25	0	0
140	0.25	0.23	0.02	8
Average	0.530714	0.6435	0.11571	16.6007

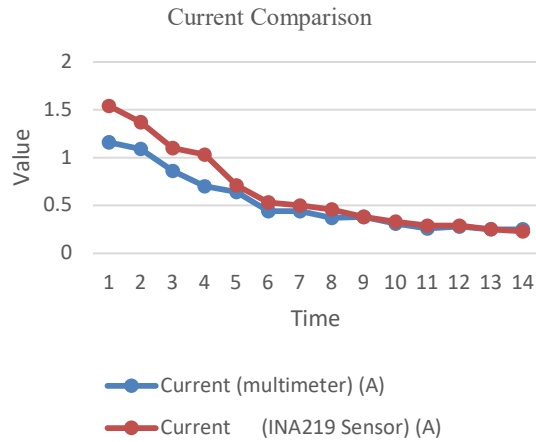

Figure 9. Comparison of current measurements using a multimeter and the INA 219 sensor in case study 2.

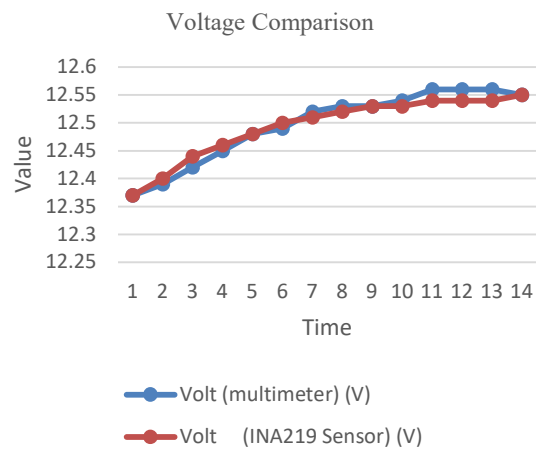

Figure 10. Comparison of Volt measurements using a multimeter and the INA 219 sensor in case study 2.

Table 4. Comparison results of volt measurements between multimeter and the INA 219 sensor in case study 2

Time (minute)	Volt (multimeter) (V)	Volt (INA219 Sensor) (V)	Difference	Error
10	12.37	12.37	0	0
20	12.39	12.4	0.01	0.08071
30	12.42	12.44	0.02	0.161031
40	12.45	12.46	0.01	0.080321
50	12.48	12.48	0	0
60	12.49	12.5	0.01	0.080064
70	12.52	12.51	0.01	0.079872
80	12.53	12.52	0.01	0.079808
90	12.53	12.53	0	0
100	12.54	12.53	0.01	0.079745
110	12.56	12.54	0.02	0.159236
120	12.56	12.54	0.02	0.159236
130	12.56	12.54	0.02	0.159236
140	12.55	12.55	0	0
Average	12.49642857	12.49357143	0.01	0.079947



Case study 3 is charging the battery using the parallel battery method with battery specifications of 12 V 3.5 Ah and 12 V 4.5 Ah. In case study 3, the current test can be seen in Table 5 and Figure 11 which shows that the charging time was 240 minutes with an average current output from the multimeter of 0.50 A and the INA 219 sensor of 0.61 A. Case study 3, sensor error of 0.2%. Meanwhile, the change in voltage during charging for 240 minutes between the multimeter and the INA 219 sensor resulted in a sensor error percentage of 0.55%. The results of the voltage test in case study 3 can be seen in Table 6 and Figure 12.

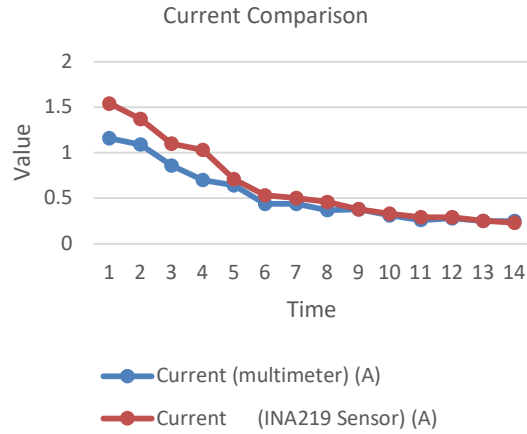

Figure 11. Comparison of current measurements using a multimeter and the INA 219 sensor in case study 3.

Table 5. Comparison results of current measurements between multimeter and the INA 219 sensor in case study 3

Time (minute)	Current (multimeter) (A)	Current (INA219 Sensor) (A)	Difference	Error
10	1.04	1.28	0.24	23.0769
20	1.02	1.23	0.21	20.5882
30	0.99	1.17	0.18	18.1818
40	0.84	1.07	0.23	27.3809
50	0.74	0.94	0.2	27.0270
60	0.62	0.86	0.24	38.7097
70	0.6	0.72	0.12	20
80	0.53	0.68	0.15	28.3018
90	0.51	0.66	0.15	29.4117
100	0.53	0.62	0.09	16.9811
110	0.46	0.54	0.08	17.3913
120	0.43	0.53	0.1	23.2558
130	0.48	0.49	0.01	2.08333
140	0.4	0.49	0.09	22.5
150	0.34	0.46	0.12	35.2941
160	0.39	0.43	0.04	10.2564
170	0.35	0.4	0.05	14.2857
180	0.3	0.37	0.07	23.3333
190	0.31	0.34	0.03	9.67742
200	0.27	0.32	0.05	18.5185
210	0.28	0.29	0.01	3.57142
220	0.23	0.28	0.05	21.7391
230	0.22	0.27	0.05	22.7272
240	0.22	0.26	0.04	18.1818
Average	0.5042	0.6125	0.108333	20.519

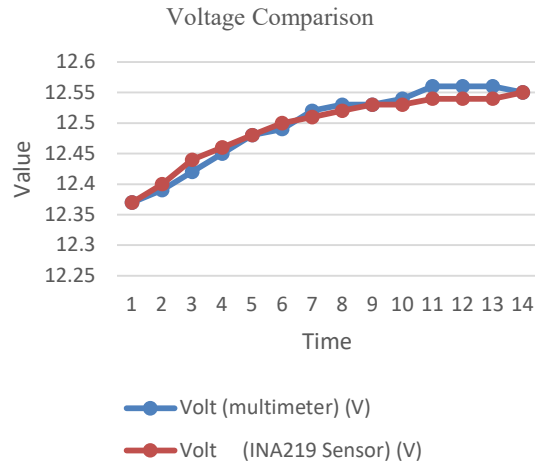

Figure 12. Comparison of Volt measurements using a multimeter and the INA 219 sensor in case study 3.

Table 6. Comparison results of volt measurements between multimeter and the INA 219 sensor in case study 3

Time (minute)	Volt (multimeter) (V)	Volt (INA219 Sensor) (V)	Difference	Error
10	12.2	12.42	0.22	1.803279
20	12.24	12.42	0.18	1.470588
30	12.27	12.43	0.16	1.303993
40	12.3	12.44	0.14	1.138211
50	12.32	12.46	0.14	1.136364
60	12.34	12.47	0.13	1.053485
70	12.35	12.48	0.13	1.052632
80	12.38	12.49	0.11	0.88853
90	12.41	12.49	0.08	0.644641
100	12.42	12.5	0.08	0.644122
110	12.44	12.5	0.06	0.482315
120	12.46	12.51	0.05	0.401284
130	12.47	12.51	0.04	0.32077
140	12.48	12.51	0.03	0.240385
150	12.49	12.52	0.03	0.240192
160	12.51	12.52	0.01	0.079936
170	12.51	12.52	0.01	0.079936
180	12.52	12.53	0.01	0.079872
190	12.53	12.53	0	0
200	12.53	12.54	0.01	0.079808
210	12.54	12.54	0	0
220	12.54	12.54	0	0
230	12.55	12.54	0.01	0.079681
240	12.56	12.55	0.01	0.079618
Average	12.43166667	12.49833333	0.0683333	0.554152

**4. CONCLUSION AND LIMITATION**

The term “Internet of Things” (IoT) describes a scenario in which real-world objects such as furniture, appliances, cars, and even humans are equipped with internet connections, software, and sensor technology that allow them to share data and communicate automatically. one another. Designed to connect IoT devices, web services and other distributed systems in an understandable data stream. Node-RED is a visual

programming environment. Using building blocks known as “nodes,” users can create visual-based workflows and connect them to produce complex application logic. This research presents battery monitoring using Node-Red. This research carried out validation using 3 case studies on battery charging. The difference in voltage from the three case studies obtained an average percentage error from the voltage sensor using the INA 219 sensor of 0.23%. There is a difference in current when charging the battery, the current becomes smaller when the voltage reaches its full limit in order to keep the battery in good condition. Testing the current from 3 case studies showed that the difference in the percentage of sensor error from the voltage using the INA 219 sensor was 0.19%. This research can be developed by adding the latest IOT and communication technology such as LORA to get its updates.

## REFERENCES



- [1] M. M. Rana et al., “Applications of energy storage systems in power grids with and without renewable energy integration—A comprehensive review,” *J. energy storage*, vol. 68, p. 107811, 2023.
- [2] W. Aribowo, “A Novel Improved Sea-Horse Optimizer for Tuning Parameter Power System Stabilizer,” *J. Robot. Control*, vol. 4, no. 1, pp. 12–22, 2023, doi: <https://doi.org/10.18196/jrc.v4i1.16445>.
- [3] A. G. Olabi, Q. Abbas, P. A. Shinde, and M. A. Abdelkareem, “Rechargeable batteries: Technological advancement, challenges, current and emerging applications,” *Energy*, vol. 266, p. 126408, 2023.
- [4] H. A. Hasan, H. Togun, A. M. Abed, N. Biswas, and H. I. Mohammed, “Thermal performance assessment for an array of cylindrical Lithium-Ion battery cells using an Air-Cooling system,” *Appl. Energy*, vol. 346, p. 121354, 2023.
- [5] E. Vasta et al., “Models for battery health assessment: a comparative evaluation,” *Energies*, vol. 16, no. 2, p. 632, 2023.
- [6] C. Wei et al., “Unraveling the LiNbO<sub>3</sub> coating layer on battery performances of lithium argyrodite-based all-solid-state batteries under different cut-off voltages,” *Electrochim. Acta*, vol. 438, p. 141545, 2023.
- [7] W. Aribowo, B. Suprianto, and J. Joko, “Improving neural network using a sine tree-seed algorithm for tuning motor DC,” *Int. J. Power Electron. Drive Syst.*, vol. 12, no. 2, p. 1196, 2021.
- [8] M. Saied, S. Guirguis, and M. Madbouly, “Review of artificial intelligence for enhancing intrusion detection in the internet of things,” *Eng. Appl. Artif. Intell.*, vol. 127, p. 107231, 2024.
- [9] S. A. Omid, M. J. A. Baig, and M. T. Iqbal, “Design and implementation of node-red based open-source SCADA architecture for a hybrid power system,” *Energies*, vol. 16, no. 5, p. 2092, 2023.
- [10] I. Gonzalez, A. J. Calderón, and F. J. Folgado, “IoT real time system for monitoring lithium-ion battery long-term operation in microgrids,” *J. Energy Storage*, vol. 51, p. 104596, 2022.
- [11] X. Wang, X. Yi, and H. Ding, “Battery Monitoring System Design Based on NB-IoT,” in *2022 First International Conference on Cyber-Energy Systems and Intelligent Energy (ICCSIE)*, 2023, pp. 1–5.
- [12] Z. E. Dallalbashi, S. Alhayalir, M. J. Mnati, and A. A. Alhayali, “Low-cost battery monitoring circuit for a photovoltaic system based on LoRa/LoRaWAN network,” *Indones. J. Electr. Eng. Comput. Sci.*, vol. 29, no. 2, pp. 669–677, 2023.
- [13] N. Bin Kamarozaman and A. H. Awang, “IOT COVID-19 portable health monitoring system using Raspberry Pi, node-red and ThingSpeak,” in *2021 IEEE Symposium on Wireless Technology & Applications (ISWTA)*, 2021, pp. 107–112.
- [14] P. Macheso, T. D. Manda, S. Chisale, N. Dzipire, J. Mlatho, and D. Mukanyiligira, “Design of ESP8266 smart home using MQTT and node-RED,” in *2021 International Conference on Artificial Intelligence and Smart Systems (ICAIS)*, 2021, pp. 502–505.
- [15] L. González, A. Gonzales, S. González, and A. Cartuche, “A Low-Cost IoT Architecture Based on LPWAN and MQTT for Monitoring Water Resources in Andean Wetlands,” *SN Comput. Sci.*, vol. 5, no. 1, p. 144, 2024.
- [16] X. Mu and M. F. Antwi-Afari, “The applications of Internet of Things (IoT) in industrial management: a science mapping review,” *Int. J. Prod. Res.*, vol. 62, no. 5, pp. 1928–1952, 2024.
- [17] F. Alwahedi, A. Aldhaheeri, M. A. Ferrag, A. Battah, and N. Tihanyi, “Machine learning techniques for IoT security: Current research and future vision with generative AI and large language models,” *Internet Things Cyber-Physical Syst.*, 2024.
- [18] K. C. Rath, A. Khang, and D. Roy, “The Role of Internet of Things (IoT) Technology in Industry 4.0 Economy,” in *Advanced IoT Technologies and Applications in the Industry 4.0 Digital Economy*, CRC Press, 2024, pp. 1–28.
- [19] P. J. Werbos, “The New AI: Basic concepts, and urgent risks and opportunities in the internet of things,” in *Artificial Intelligence in the Age of Neural Networks and Brain Computing*, Elsevier, 2024, pp. 93–127.
- [20] V. Sámano-Ortega, O. Arzate-Rivas, J. Martínez-Nolasco, J. Aguilera-Álvarez, C. Martínez-Nolasco, and M. Santoyo-Mora, “Multipurpose Modular Wireless Sensor for Remote Monitoring and IoT Applications,” *Sensors*, vol. 24, no. 4, p. 1277, 2024.
- [21] L. Thomas, M. K. MV, S. D. SL, and P. BS, “Towards Comprehensive Home Automation: Leveraging the IoT, Node-RED, and Wireless Sensor Networks for Enhanced Control and Connectivity,” *Eng. Proc.*, vol. 59, no. 1, p. 173, 2024.
- [22] C. Orłowski and M. Adrych, “Model of IoT design decision-making processes in Flow Based Programming systems,”

- J. Inf. Telecommun., pp. 1–10, 2024.
- [23] M. Weqar, S. Mehruz, D. Gupta, and S. Urooj, “Adaptive Switching Based Data-Communication Model for Internet of Healthcare Things Networks,” IEEE Access, 2024.
- [24] S. Sharma and P. Randhawa, “IoT-Powered AC Temperature Management for Eco-Smart Infrastructures,” in 2024 2nd International Conference on Intelligent Data Communication Technologies and Internet of Things (IDCIoT), 2024, pp. 59–63.
- [25] D. Hercog, T. Lerher, M. Truntič, and O. Težak, “Design and implementation of ESP32-based IOT devices,” Sensors, vol. 23, no. 15, p. 6739, 2023.

## BIOGRAPHIES OF AUTHORS

	<p><b>Nur Vidia Laksmi B.</b>    received her B.A.Sc. degree from the Electronic Engineering Polytechnic Institute of Surabaya, Indonesia, in 2015 and her M.Sc. degree from the Department of Electrical Engineering, National Taiwan University of Science and Technology (NTUST), Taiwan, in 2018. Currently, she is a lecturer in the Department of Electrical Engineering, Universitas Negeri Surabaya, Surabaya, Indonesia. Her research interests include power electronics, motor drives, and the application of control theories. She can be contacted at email: <a href="mailto:nurvidialaksmi@unesa.ac.id">nurvidialaksmi@unesa.ac.id</a>.</p>
	<p><b>Muhammad Syahril Mubarak</b>    received his B.A.Sc. degree from the Electronic Engineering Polytechnic Institute of Surabaya, Indonesia, in 2015, and M.Sc. and Ph.D. degrees in electrical engineering from the National Taiwan University of Science and Technology, Taipei, Taiwan, in 2018 and 2023, respectively. His research interests include electric drive systems and model predictive control. Currently, he is a lecturer in the Department of Engineering, Universitas Airlangga, Surabaya, Indonesia. He can be contacted at email: <a href="mailto:syahril.mubarak@ftmm.unair.ac.id">syahril.mubarak@ftmm.unair.ac.id</a>.</p>
	<p><b>Reza Rahmadian</b>    received received his Bachelor of Applied Science from ElectronicEngineering Polytechnic Institute of Surabaya (PENS), Surabaya, Indonesia, in 2006, and his Master of Engineering Science from Curtin University, Australia, in 2013. He is currently alecturer at the Department of Electrical Engineering, Universitas Negeri Surabaya, Indonesia. His research interests include renewable energy. He can be contacted at email: <a href="mailto:rezarahmadian@unesa.ac.id">rezarahmadian@unesa.ac.id</a></p>
	<p><b>Mahendra Widyartono</b>    received his Bachelor of Engineering from SepuluhNopember Institute of Technology (ITS), Surabaya, Indonesia, in 2006, and his Master ofEngineering from Brawijaya University, Indonesia, in 2012. He is currently a lecturer at the Department of Electrical Engineering, Universitas Negeri Surabaya, Indonesia. His researchinterests include power system and renewable energy. He can be contacted at email: <a href="mailto:mahendrawidyartono@unesa.ac.id">mahendrawidyartono@unesa.ac.id</a></p>
	<p><b>Ayusta Lukita Wardani</b>    received her Bachelor of Applied Science fromElectronic Engineering Polytechnic Institute of Surabaya (PENS), Surabaya, Indonesia, in 2011, and her Master of Engineering from Sepuluh Nopember Institute of Technology (ITS), Indonesia, in 2017. She is currently a lecturer at the Department of Electrical Engineering, Universitas Negeri Surabaya, Indonesia. Her research interests include renewable energy. Shecan be contacted at email: <a href="mailto:ayustawardani@unesa.ac.id">ayustawardani@unesa.ac.id</a></p>



**Aditya Chandra Hermawan**    received her Bachelor of Applied Science from Electronic Engineering Polytechnic Institute of Surabaya (PENS), Surabaya, Indonesia, and his Master of Engineering from Sepuluh Nopember Institute of Technology (ITS), Indonesia. He is currently a lecturer at the Department of Electrical Engineering, Universitas Negeri Surabaya, Indonesia. His research interests include power system engineering. He can be contacted at email: [adityahermawan@unesa.ac.id](mailto:adityahermawan@unesa.ac.id)