

Air Pollution Quality Monitor (CO, CO₂, PM2.5) at Surabaya State University

Maresa Nei Britama Damanik^{1*}, Lilik Anifah²

Bachelor of Electrical Engineering, Faculty of Engineering, Surabaya State University
maresa.21092@mhs.unesa.ac.id

Abstract - Exposure to air pollution inhaled every day greatly impacts health. Air pollution occurs anywhere, including in the environment of Surabaya State University. Air pollution originates from vehicle emission gases, combustion activities, and other sources. Due to limitations in obtaining air quality information within Surabaya State University, this study aims to facilitate monitoring of air pollution quality (CO, CO₂, PM2.5) within Surabaya State University to improve health quality. This air pollution monitor can measure the concentration of CO, CO₂, and PM2.5 where the MQ-7 sensor detects CO (carbon monoxide) gas concentrations, the MQ-135 sensor detects CO₂ (carbon dioxide) gas concentrations, DSM501A sensors detect PM2.5 (particulate) concentrations, and the use of IoT as a medium for delivering air pollution quality information that can be accessed through air pollution monitoring websites anywhere and anytime. The pollution monitoring tool has a fairly good performance in measuring the quality of air pollution (CO, CO₂, PM2.5) in the environment of Surabaya State University, with an average MQ-7 sensor reading accuracy of 87%, an average MQ-135 sensor reading accuracy of 96.44% and an average DSM501A sensor reading accuracy of 90.68% and can send air pollution monitoring results to the website in real-time.

Keywords: Pollution monitor, MQ-7, MQ-135, DSM501A, website.

INTRODUCTION

The main need for human survival is the air that is breathed. Air quality is one of the reflections of public health in a country. Exposure to air pollution inhaled daily is very influential on health. Based on IQAir data, a Swiss air quality technology company, that is engaged in protection against pollutants in the air, data shows that in 2023 Indonesia occupies the 5th position as a country with unhealthy air quality. Indonesia's air quality index of 152 is in the unhealthy category. Air pollution can occur anywhere, including in the environment of Surabaya State University. Without realizing it, every day in the environment of Surabaya State University there has been air pollution sourced from vehicle emission gases, combustion activities, and other sources. The worse the quality of the air breathed the more losses will result. The problem faced is due to limitations in obtaining air quality information within Surabaya State University, this study was made to facilitate air pollution quality monitoring (CO, CO₂, PM2.5) within Surabaya State University as a form of improving health quality.

Some previous studies related to the design of air pollution monitors include, such as research that has been conducted [1] where monitoring systems have been created to detect CO and CO₂ gas concentrations and send notification information via Telegram. However, in this study air pollution monitoring information can only be accessed through one Telegram user, the study also does not categorize the quality of air pollution concentrations and only detects two types of pollutants.

Research that has been done [2] makes CO, O₃, PM10, and PM2.5 concentration measuring devices. However, this study is not yet IoT-based so air concentration information

is only displayed through the display on the device. Research conducted [3] made a device capable of measuring the temperature and density of dust. In this study, only one type of air pollution was detected, namely dust particulates, and the dust density results were only displayed on displays not yet IoT-based.

Research conducted by [4] designed CO and CO₂ hazardous gas measuring devices in industrial environments. This research is not yet IoT-based and the tool created only detects two types of gases. The pollutant detection system created by [5] this system detects CO gas and alcohol, but this system is only equipped with information between Low and High when a hazardous gas is detected and does not display the amount of concentration of harmful gas detected. The system created is not yet IoT-based.

In previous studies there were several weaknesses, therefore this study proposed an air quality monitoring design that was able to measure three types of concentrations of pollutant gases in the air (CO, CO₂, and PM2.5). This air pollution monitor can measure concentrations of CO, CO₂, and PM2.5 where the MQ-7 sensor detects CO (carbon monoxide) gas concentrations, the MQ-135 sensor detects CO₂ (carbon dioxide) gas concentrations, DSM501A sensors detect PM2.5 (particulate) concentrations, and the use of the IoT platform, ThingSpeak as a medium for delivering air pollution quality information that is easily accessible anywhere and anytime.

This research is expected to contribute to raising awareness of the adverse effects that can be caused by exposure to harmful pollutant gases to improve health quality and as an air quality monitor within Surabaya State University.

METHODS

Research Flow

This research is carried out by following the research stages that have been prepared previously so that the process of implementing the research carried out can run according to the procedure. The first stage is to identify the problem to find a topic to be used as research material. The second stage is literature study, information search, and references related to previous research sourced from journals, and articles.

The third stage is tool design and programming. Through the theory obtained, hardware design and software programming are carried out by the research conducted. The fourth stage is tool testing. Testing and calibration of MQ-7, MQ-135, and DSM501A sensors. The fifth stage is data collection and analysis. Data collection was carried out for 2 days directly in two locations, namely the parking lot of the Faculty of Engineering and the gazebo of building A3 located in the Surabaya State University environment, followed by analysis of test result data. The sixth stage, the last stage where conclusions are drawn from the results of the analysis of test data which is the answer to the problem formulation.

System Design

The design of an air pollution quality monitoring system (CO, CO₂, PM_{2.5}) within Surabaya State University is shown in the block diagram in Figure 1.

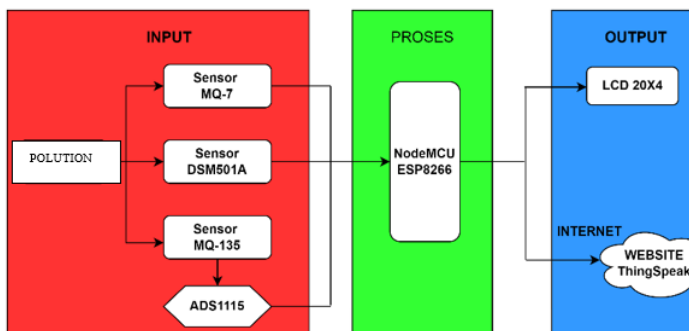

Figure 1. Block Diagram

The block diagram is divided into three interconnected parts, namely, input, consisting of MQ-7 sensors to detect CO pollutant gas, MQ-135 to detect CO₂ pollutant gas, DSM501A to detect PM_{2.5} and ADS1115 pollution. Processes, namely NodeMCU microcontrollers ESP8266. The output consists of a 20x4 LCD and ThingSpeak.

Hardware Design

Hardware design of air pollution quality monitors (CO, CO₂, PM_{2.5}) within Surabaya State University to find out the wiring of the components used. Hardware design can be seen in Figure 2.

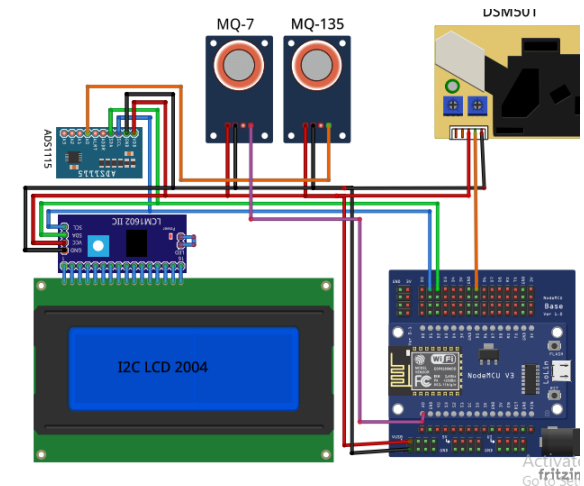

Figure 2. Design Hardware

The implementation of the hardware design is shown in Figure 3.

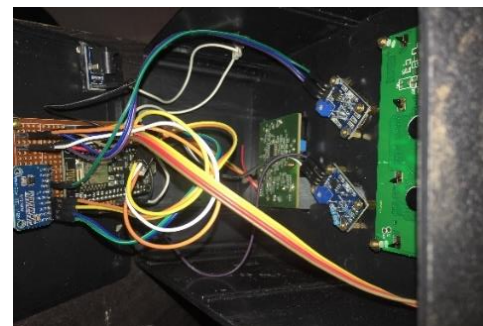

Figure 3. The implementation of the hardware design

MQ-7 Sensor Output Value Conversion

MQ-7 sensor to detect CO pollutant gas. Conversion of sensor reading values in PPM units is carried out with the following stages:

1. Convert the sensor value to an analog voltage value using Equation 1, where the ADC value is the digital data value read by the sensor output by the microcontroller through the internal ADC. ADC bit resolution of NodeMCU ESP8266 is $2^{10} = 1024$ and Volt resolution (3.3 Volts).

$$VRL = \frac{\text{ADC Value}}{\text{ADC Bit Resolution}} \times \text{Volt resolution} \quad (1)$$

2. Furthermore, determining the amount of Rs from the sensor reading using Equation 2, RL is a load resistance whose magnitude can be adjusted to the needs, in this study RL = 20KΩ was used.

$$R_s = \frac{V_c - VRL}{VRL} * RL \quad (2)$$

Vc = Source Voltage (5Volt)

VRL = Output voltage from analog

3. The magnitude of the Ro value is determined using Equation 3, where the Ro value is determined based on the CO concentration obtained from a tool capable of measuring the CO concentration value (1PPM) in the surrounding environment. The magnitude of the Ro value is determined

the first time the sensor is used after preheating before programming. In this study the value of $R_o = 6900\Omega$.

$$PPM = ax^b \quad (3)$$

$$x = ratio = \frac{R_s}{R_o} \quad (4)$$

values of a and b are obtained from the equation of the characteristic graph of the MQ-7 sensor. A graphic of the characteristics of the MQ-7 sensor is shown in Figure 4. Sensor characteristic equations are obtained with Ms. Excel software by utilizing the scatter, scatter with smooth lines, and markers features. Then click on the line and select Add Trendline, select Power, and Display Equation on Chart. Furthermore, the Display Equation on Chart command will display the y-line equation (PPM) as a function of x (R_s/R_o) [6]. The characteristic curve of the MQ-7 sensor is shown in Figure 5.

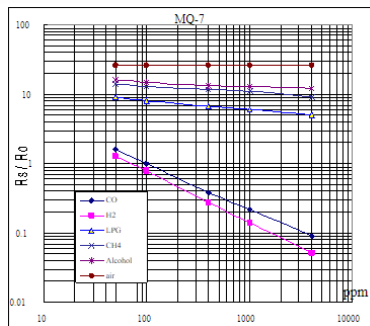

Figure 4. MQ-7 Sensor Characteristic Graph

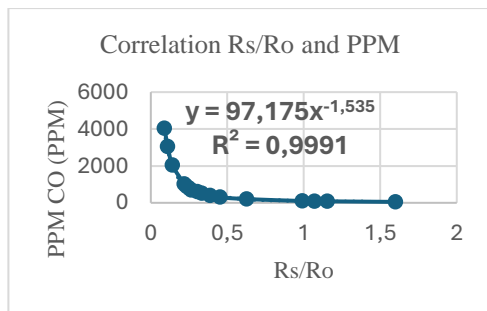

Figure 5. MQ-7 Sensor Characteristic Curve

The equation obtained $y = PPM = 97.175 X^{-1.535}$ Where $a = 97.175$ and $b = -1.535$ are used as equations to convert analog voltage values into PPM units.

MQ-135 Sensor Output Value Conversion

The MQ-135 sensor is used to detect CO_2 pollutant gas. The conversion of sensor reading values in PPM units is carried out with the following stages:

1. The limitation of analog pins that only exist 1 on the NodeMCU microcontroller is that the MQ-135 sensor is connected to an ADS1115 that functions to read the analog value of the sensor and uses the ADS1115 library to obtain voltage values from analog data read by the sensor.

2. Next, determine the amount of R_s from the sensor reading using Equation 1, R_L is the load resistance whose magnitude can be adjusted to the needs. In this study, $R_L = 10K\Omega$ was used.

3. The R_o value is determined using Equation 3, where the R_o value is determined based on the concentration of CO_2 obtained from a tool capable of measuring the value of CO_2 concentration (410 PPM) in the surrounding environment. The magnitude of the R_o value is determined the first time the sensor is used after preheating before programming. In this study the value of $R_o = 66K\Omega$.

4. Next, to determine the value of CO_2 gas concentration in PPM units, Equation 3 is used, where values a and b are obtained from the characteristic graph of the MQ-135 sensor. The characteristic graph is shown in Figure 6.

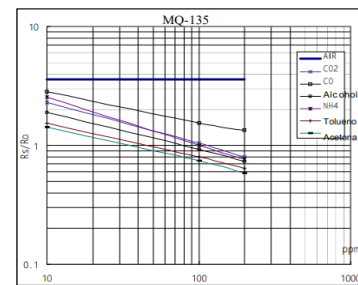

Figure 6. MQ-135 Sensor Characteristics Graph

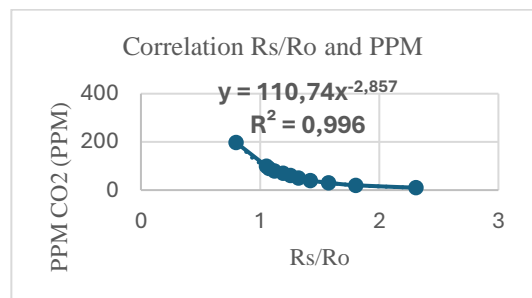

Figure 7. MQ-135 Sensor Characteristic Curve

Using the same method as in the MQ-7 sensor, the equation obtained is $y = PPM = 110.74 X^{-2.857}$

Where $a = 110.74$ and $b = -2.857$ are used as equations to convert analog voltage values into PPM units.

DSM501A Sensor Output Value Conversion

The sensor DSM501A to detect $PM_{2.5}$. DSM501A works by sending low pulses and summing up low pulses over a fixed period of 30 seconds. Usage example: By monitoring the low pulse for 30 seconds and getting a low pulse of 1000 ms (1 second), then dividing 1/30 so that it will give a low ratio. This is indicated by the following code:

```
floatratio=(lowpulseInMicroSeconds/1000000.0)/30.0*100.0; //Calculate ratio
```

The conversion of sensor readings DSM501A is based on a graph of the characteristic relationship between low ratio to concentration. A graph of DSM501A sensor

characteristics is shown in Figure 8. The characteristic curve of the sensor DSM501A is shown in Figure 9.

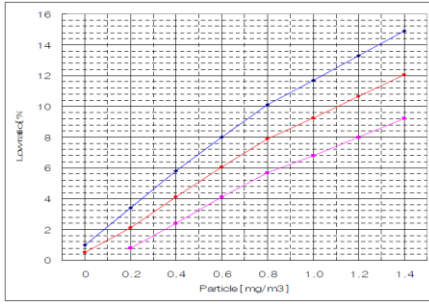

Figure 8. Sensor DSM501A Characteristic Graph

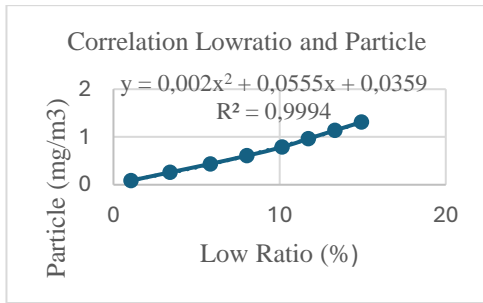

Figure 9. Sensor DSM501A Characteristic Curve

The equation obtained from the characteristic graph is $y = 0.002x^2 + 0.0555x + 0.0359$ where y is the particle concentration value while x is the row ratio value of the sensor reading. The equation will be entered into programming to get the value of the concentration of dust particles.

Software Design

The flowchart of the system is shown in Figure 10.

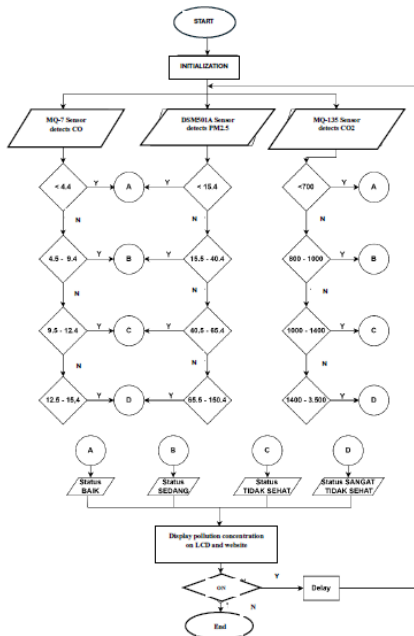

Figure 10. Flowchart

The flowchart of the system illustrates how the entire air pollution quality monitoring system runs. The concentration limits of CO and PM2.5 pollutant gases are shown in Figure 11. The concentration limit of the CO₂ pollutant gas is shown in Figure 12.

O ₃ (ppm)	PM ₁₀ (ug/m ³)	PM _{2.5} (ug/m ³)	CO (ppm)	SO ₂ (ppm)	NO ₂ (ppm)	AQI Values	Level of Health Concern
0.000 – 0.059	0 – 54	0.0 – 15.4	0.0 – 4.4	0.000 – 0.034	–	0 – 50	Good
0.060 – 0.075	55 – 154	15.5 – 40.4	4.5 – 9.4	0.035 – 0.144	–	51 – 100	Moderate
0.076 – 0.095	155 – 254	40.5 – 65.4	9.5 – 12.4	0.145 – 0.224	–	101 – 150	Unhealthy for Sensitive Groups
0.096 – 0.115	255 – 354	65.5 – 150.4	12.5 – 15.4	0.225 – 0.304	–	151 – 200	Unhealthy
0.116 – 0.374	355 – 424	150.5 – 250.4	15.5 – 30.4	0.305 – 0.604	0.65 – 1.24	201 – 300	Very Unhealthy
–	425 – 504	250.5 – 350.4	30.5 – 40.4	0.605 – 0.804	1.25 – 1.64	301 – 400	Hazardous
–	505 – 604	350.5 – 500.4	40.5 – 50.4	0.805 – 1.004	1.65 – 2.04	401 – 500	Hazardous

Figure 11. Limits of CO and PM2.5 Pollutant Gas Values and Categories

CO ₂ poisoning caused risks:	CO ₂ ppm benchmarks		
	ppm	air quality	action
▪ Headache	350-700	good	urban air outdoors; recommended for common rooms
▪ Nausea	> 1,000	borderline	wellbeing is disturbed; increased ventilation measures necessary
▪ Dizziness	800-1,400	bad	air in poorly ventilated flats, limit in offices
▪ Shortness of breath	1,400-3,500	stressful	maximum values in the classroom after a lesson; intensive ventilation required
▪ Disturbance of consciousness to unconsciousness	> 2,000	unacceptable	professional ventilation concept required
▪ Respiratory disorder to respiratory arrest	> 3,500	unacceptable	maximum measured values in cinemas after a movie
	40,000		exhaled air by humans

Figure 12. CO₂ Concentration Category Index Limits

In this study, air pollution quality categories consist of 4, namely Baik (B), Sedang (S), Tidak Sehat (TS), and Sangat Tidak Sehat (STS). The quality of the air pollution will be displayed on the LCD.

Design ThingSpeak

The use of the ThingSpeak IoT platform as a medium for delivering information on air pollution concentration values that can be accessed anywhere and anytime. The initial stage of designing ThingSpeak begins with visiting the page ThingSpeak.com followed by registering a ThingSpeak account. In the channel added as many as 3 fields for CO, CO₂, and PM2.5 gas data and chose public access. After the channel is successfully added to the API Keys section, there is a write API key to send data and a read API key to read data. The API key obtained will be listed in the Arduino IDE programming so that sensor reading information can be displayed on the ThingSpeak page. Publicly accessible via <https://bit.ly/PemantauPolusi> display as shown in Figure 13.

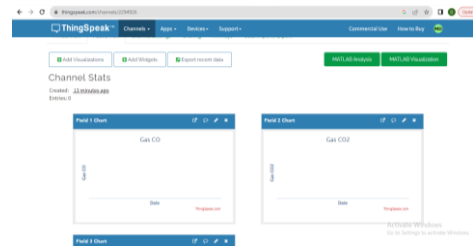

Figure 13. ThingSpeak Air Pollution Quality Monitor

RESULT AND DISCUSSION

The results of this study have successfully monitored the quality of air pollution, but to get a more accurate value, calibration of each sensor is needed.

MQ-7 Sensor Calibration

The value of the sensor reading is compared with the comparison device of the KKMOON Air Quality Detector calibrator. The test results of the MQ-7 sensor are shown in Table 1.

Table 1. MQ-7 Sensor and Calibrator Test Results

Test	MQ-7 Sensor (PPM)	Calibrator (PPM)	Error (%)
1	0.87	2	56.5
2	0.87	2	56.5
3	0.95	2	52.5
4	0.55	1	45
5	0.87	2	56.5
6	0.55	1	45
7	0.55	1	45
8	0.9	2	55
9	0.66	1	34
10	0.55	1	45

Data from the test results are then calibrated using the linear regression method using Microsoft Excel software. A graph of approximation is obtained as shown in Figure 14, and a graphic equation is obtained that will be included in the programming as follows:

$$y = 0.32x + 0.252$$

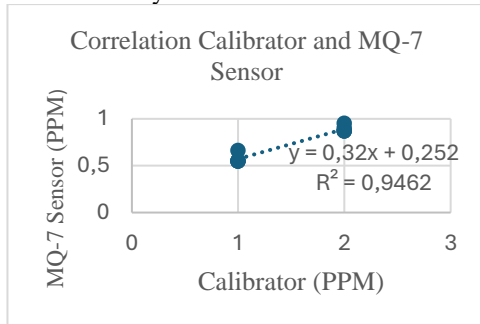

Figure 14. Graph of the Relationship of Calibrator and Sensors MQ-7

MQ-135 Sensor Calibration

Test results of the MQ-135 sensor and calibrator are shown in Table 2.

Table 2. MQ-135 Sensor Test and Calibration Results

Test	MQ 135 Sensor (PPM)	Calibrator (PPM)	Error (%)
1	237,23	403	41,1017
2	237,23	403	41,1012
3	236,53	402	41,1617
4	236,53	402	41,1617
5	262,65	409	35,7824
6	250,20	406	38,3744
7	278,72	410	32,0195
8	278,72	410	32,0195
9	259,34	407	36,2801

10	259,34	407	36,2801
----	--------	-----	---------

Data from the test results are then calibrated using the linear regression method using Microsoft Excel software. A graph of the approximation as shown in Figure 15 is obtained, and a graphic equation is obtained that will be included in the programming as follows:

$$y = 5,0987x - 1815,9$$

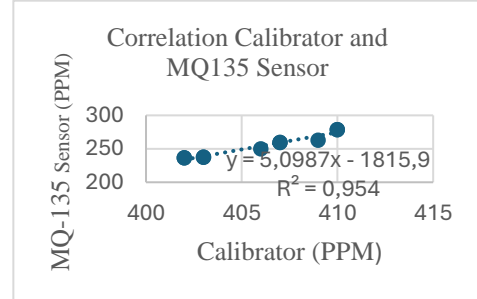

Figure 15. Graph of the Relationship of Calibrator and Sensors MQ-135

DSM501A Sensor Calibration

Test results of dsm501A sensor and calibrator are shown in Table 3.

Table 3. Results Test DSM501A Sensor and Calibrator

Test	DSM501A ($\mu\text{g}/\text{m}^3$)	Calibrator ($\mu\text{g}/\text{m}^3$)	Error (%)
1	35.90	25	43.6
2	35.90	24	49.58333
3	35.90	26	38.07692
4	45.99	30	53.3
5	45.99	30	53.3
6	35.90	26	38.07692
7	35.90	26	38.07692
8	45.99	29	58.58621
9	45.99	30	53.3
10	35.90	24	49.58333

A graph of approximation is obtained as shown in Figure 16, and a graphic equation is obtained that will be included in the programming as follows:

$$y = 1.982x - 13.577$$

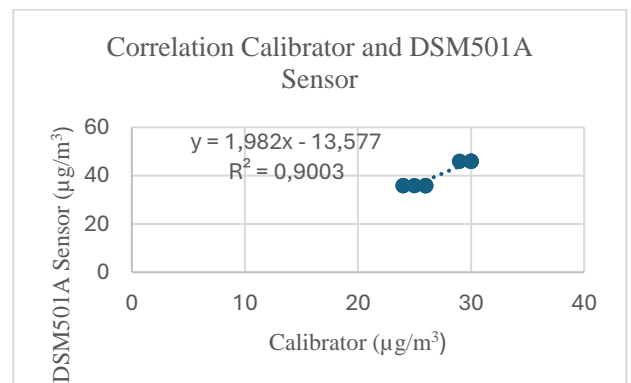

Figure 16. Graph of Relationship Calibrator and DSM501A

Testing Of The System

Air pollution quality monitoring system testing was carried out for 2 days of testing at the parking location of the Faculty of Engineering and Gazebo building A3 Surabaya State University from 08.00 to 16.00 WIB. The results of the first day's testing are shown in Table 4.

Table 4. Day One Test Results

No	Time (WIB)	Result			Calibrator			Error (%)		
		CO PPM	CO ₂ PPM	PM2.5 µg/m ³	CO PPM	CO ₂ PPM	PM2.5 µg/m ³	CO	CO ₂	PM2.5
1	08.00	0.8 (B)	513 (B)	25 (S)	1	496	22	20	3.4	13.6
2	08.30	0.85 (B)	549 (B)	25 (S)	1	506	22	15	6.31	13.6
3	09.00	0.79 (B)	428 (B)	25 (S)	1	411	26	21	4.13	4
4	09.30	0.80 (B)	446 (B)	25 (S)	1	423	22	20	3.42	13.6
5	10.00	0.72 (B)	415 (B)	25 (S)	1	409	24	28	1.46	4.16
6	10.30	2.12 (B)	489 (B)	25 (S)	2	475	22	6	2.94	13.6
7	11.00	2.12 (B)	492 (B)	25 (S)	2	475	24	6	3.57	4.16
8	11.30	1.84 (B)	391 (B)	25 (S)	2	421	28	8	7.12	10.7
9	12.00	1.90 (B)	413 (B)	25 (S)	2	455	24	5	9.23	4.16
10	12.30	1.47 (B)	520 (B)	30 (S)	2	529	29	26	1.7	3.44
11	13.00	1.2 (B)	443 (B)	25 (S)	1	419	25	20	5.7	0
12	13.30	1.02 (B)	416 (B)	25 (S)	1	414	28	2	0.48	10.7
13	14.00	1.07 (B)	404 (B)	25 (S)	1	417	30	7	3.11	16.6
14	14.30	2.4 (B)	434 (B)	25 (S)	2	430	30	20	0.93	16.6
15	15.00	1.84 (B)	432 (B)	25 (S)	2	416	26	8	3.8	3.8
16	15.30	1.84 (B)	433 (B)	25 (S)	2	417	24	8	3.8	4.16
17	16.00	1.3 (B)	460 (B)	25 (S)	1	445	29	30	3.37	13.7
Average error sensor (%)								14.7	3.7	8.8

The first day's testing at the Surabaya State University parking lot is shown in Figure 17.



Figure 17. First Day Testing

The second day of testing was carried out at the gazebo location of Building A3 of Surabaya State University from 08.00 to 16.00 WIB. The test results are shown in Table 5.

Table 5. Day Two Test Results

No	Time (WIB)	Result			Calibrator			Error (%)		
		CO PPM	CO ₂ PPM	PM2.5 µg/m ³	CO PPM	CO ₂ PPM	PM2.5 µg/m ³	CO	CO ₂	PM2.5
1	08.00	1.3 (B)	439 (B)	25 (S)	1	406	21	30	8.1	19
2	08.30	2.2 (B)	435 (B)	25 (S)	1	407	28	10	6.8	10.7
3	09.00	2.3 (B)	412 (B)	25 (S)	2	409	22	15	0.7	13.6
4	09.30	2.75 (B)	416 (B)	33 (S)	3	410	29	8.3	1.46	13.7
5	10.00	2.1 (B)	404 (B)	25 (S)	2	411	25	5	1.7	0
6	10.30	2 (B)	413 (B)	25 (S)	2	411	24	0	0.48	4.16
7	11.00	2.4 (B)	413 (B)	25 (S)	2	405	24	20	1.97	4.16
8	11.30	2.46 (B)	428 (B)	25 (S)	3	411	29	18	4.13	13.7
9	12.00	2.75 (B)	430 (B)	26.4 (S)	3	404	29	8.3	6.4	8.96
10	12.30	2.1 (B)	436 (B)	25 (S)	2	407	21	5	7.12	19
11	13.00	1.68 (B)	396 (B)	25 (S)	2	406	22	16	2.46	13.6
12	13.30	1.63 (B)	404 (B)	25 (S)	2	411	30	18.5	1.7	16.6
13	14.00	2.1 (B)	399 (B)	25 (S)	2	405	22	5	1.48	13.6
14	14.30	2.3 (B)	409 (B)	27 (S)	2	404	26	15	1.23	3.8
15	15.00	1.90 (B)	429 (B)	25 (S)	2	410	26	5	4.6	3.8
16	15.30	2.06 (B)	409 (B)	25 (S)	2	408	26	3	0.24	3.8
17	16.00	2.2 (B)	433 (B)	25 (S)	2	409	26	10	5.8	3.8
Average error sensor (%)								11.3	3.31	9.7

The error percentage is calculated using the following equation:

$$\text{error (\%)} = \frac{\text{Measurable data} - \text{Reference data}}{\text{Reference data}} \times 100\% \quad (5)$$

Furthermore, to find out the accuracy results in the system using the following equations:

$$\text{Accuracy} = 100\% - \text{error (\%)} \quad (6)$$

To calculate the average accuracy of the system, use the following equation:

$$\text{average accuracy} = \frac{\text{Total of accuracy}}{\text{Number of data}} \quad (7)$$

The results of tests conducted for two days show that the MQ-7 sensor detects the lowest concentration of CO of 0.72 PPM and the highest of 2.75 PPM, the MQ-135 sensor detects the lowest concentration of CO₂ of 391 PPM and the highest of 549 PPM and the DSM501A sensor detects PM2.5 as low as 25µg/m³ and the highest 33 µg/m³. From the test data results, calculations were made and the average accuracy of pollutant gas concentration readings by the system was obtained with an average accuracy of CO gas readings by the MQ-7 sensor of 87%, the average accuracy of CO₂ gas readings by the MQ-135 sensor of 96.44% and the average accuracy of PM2.5 readings by the DSM501A sensor of 90.68%.

ThingSpeak Testing

The application of the use of IoT in tools made using the IoT platform Thingspeak. The test results on ThingSpeak that have been created as IoT utilization can be seen in Figure 18.

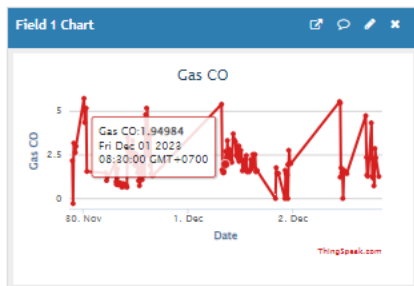

(a)

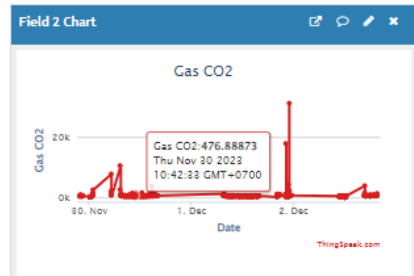

(b)

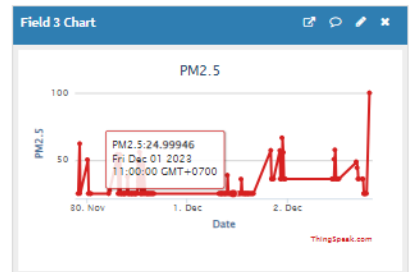

(c)

Figure 18. Graph of Test Results on ThingSpeak (a) CO Gas, (b) CO₂ Gas, (c) PM2.5

CONCLUSION

After completing this research, it was concluded that the research carried out had succeeded in designing and building air pollution quality monitors within Surabaya State University. The MQ-7 sensor detects CO gas concentration, the MQ-135 sensor detects CO₂ gas concentration and the DSM501A sensor detects dust particle concentration quite well. The monitoring tool is also capable of sending and displaying air pollution concentration data on ThingSpeak.

The accuracy value of CO concentration is 87%, the accuracy value of CO₂ concentration is 96.44% and the accuracy value of PM2.5 concentration is 90.68%. Air pollution quality monitoring tools can categorize air pollution concentrations of CO, CO₂, and PM2.5 according to predetermined regulations.

For further development of this study, several suggestions were given where additional types of pollutants can be detected so that air quality information is more complete. The calibration process can be carried out in the laboratory so that the data obtained is more accurate. Further research with other sensor calibration methods that consider

the influence of temperature, humidity, and wind speed can affect gas sensor value readings.

REFERENCES

- [1] D. Kurniawan, S. R. Sulistiyanti, and U. Murdika, "SISTEM PEMANTAU GAS KARBON MONOKSIDA (CO) DAN KARBON DIOKSIDA (CO₂) MENGGUNAKAN SENSOR MQ7 DAN MQ-135 TERINTEGRASI TELEGRAM," *Jurnal Informatika dan Teknik Elektro Terapan*, vol. 11, no. 2, Apr. 2023, doi: 10.23960/jitet.v11i2.2963.
- [2] T. S. Gunawan, Y. M. S. Munir, M. Kartiwi, and H. Mansor, "Design and implementation of portable outdoor air quality measurement system using arduino," *International Journal of Electrical and Computer Engineering*, vol. 8, no. 1, pp. 280–290, Feb. 2018, doi: 10.11591/ijece.v8i1.pp280-290.
- [3] M. K. Fadzly, Yiling, M. F. Rosli, T. Amarul, and M. S. M. Effendi, "Smart Air Quality Monitoring System Using Arduino Mega," in *IOP Conference Series: Materials Science and Engineering*, IOP Publishing Ltd, Jul. 2020. doi: 10.1088/1757-899X/864/1/012215.
- [4] E. Nebath, D. Pang, and J. O. Wuwung, "Rancang Bangun Alat Pengukur Gas Berbahaya CO Dan CO₂ di Lingkungan Industri," 2014.
- [5] A. A. Rosa, B. A. Simon, and K. S. Lieanto, "Sistem Pendeteksi Pencemar Udara Portabel Menggunakan Sensor MQ-7 dan MQ-135," *ULTIMA Computing*, vol. XII, no. 1, 2020.
- [6] H. Subagiyo et al., "Rancang Bangun Sensor Node untuk Pemantauan Parameter Kualitas Udara," *Jurnal Sains, Teknologi dan Industri*, vol. 18, no. 1, pp. 72–79, 2020.