

# Distance Detection in the Sport of Petanque Using the VL53L0X Time-of-flight

Moch. Fahmy Rizki Rizaldy<sup>1</sup>, Lilik Anifah<sup>2</sup>  
Universitas Negeri Surabaya  
Jurusan Teknik Elektro, Kampus Unesa Ketintang  
<sup>1,2</sup>Ketintang, Surabaya 60231, Indonesia  
mochrizaldy.19037@mhs.unesa.ac.id  
lilikanifah@unesa.ac.id

**Abstract** - Technology as a means to facilitate human activities is currently being applied in various fields of activity due to its rapid development. The implementation of technology has also penetrated the field of sports as a physical activity and as a solution for human physical health. Sports progress is based on the optimal state of human resources, facilities, and management. With technology in the world of sports, more advanced sports are also in harmony with existing technological developments. In other sports, technology has been utilized to support and optimize the course of the sport, for example, in football with VAR and badminton with hawk-eye. Therefore, the sport of petanque, which was first popularized in Indonesia at the Sea Games in Palembang, has the potential to develop with various improvements through the use of technology. The urgency faced is at the stage of measuring the distance of the ball to decide on awarding points to the team that is entitled to a Petanque match. The measuring devices and methods used are still conventional and have the potential to produce inaccurate distance values and decisions. The accuracy of the distance measurement results obtained using conventional tools and methods is questionable and raises doubts due to various factors. With the existence of distance measurement technology, it will help the referee's performance as a Petanque match court in making point decisions. The use of the VL53L0X time-of-flight (ToF) sensor has great potential because it has the advantage of good accuracy and is not affected by noise that affects the measurement results. By using the Arduino Uno R3 as a regulatory and process microcontroller and a KY-008 laser to direct and indicate the ToF sensor right at the target object. From the tests carried out, it was found that the maximum accuracy value of the prototype reached 98.45% with a standard deviation of 3.01.

**Keywords:** time-of-flight, VL53L0X, measurement, sports, petanque

## I. INTRODUCTION

Technology, which is an object intended to facilitate human activities [1], is also used to improve the efficiency and effectiveness of these activities in everyday life [2]. The development of this technology is growing quite rapidly, with implementation in various fields. Sport as a physical activity for solutions to human physical health that affects their survival can, in fact, form a separate culture in social life that contains values such as sportsmanship, ethics, morals, and respect for others [3]. technology in related aspects. The values in sports are directly proportional to optimal and positive conditions in human resources, facilities, and sports management, so that progress is also achieved in sports [3], [4]. In the use of technology, the sports sector also implements, progresses, and keeps abreast of developments [5]. Advances and developments in technology and sports are directly proportional to each other [3]. There have been many roles for technology in its application in sports, such as football and badminton. In football, it is known that the use of VAR (Video Assistant Referees) with a monitor screen that will be examined by the referee displays the identification of violations, goals, and penalty kicks and is on the side of the field. Of course, it is

useful to assist the referee in adjudicating the course of the game, especially in making the right decisions. In critical and controversial situations [4], in badminton, there is a technology called Hawk-eye, which is equipped with eight sophisticated cameras that are also to assist referees in making decisions, and in practice, it is very helpful for players to raise objections to decisions from line judges [6]. Talking about the development and application of technology in other sports, there is one sport with potential, namely petanque.

Petanque (pronounced Pe tak) is a sport of dexterity in throwing metal balls (called boules) to approach a target ball made of wood (called a jack), originating from France. It is a sport that is still not popular in Indonesia [7]. It first entered Indonesia in 2011 when the Sea Games event was held in Palembang and was contested [8], which was then competed in various national events such as Regional Championship, National Championship, POMNAS, PON, Sea Games, and other national open events [9]. FOPI (Indonesian Petanque Sports Federation), as the official organization of Petanque Indonesia, is part of the Asian Boules Sport Confederation under the auspices of FIPJP (Fédération Internationale de Pétanque et Jeu Provençal), which is the parent organization of the world sport of Petanque. The boules used are 70–80 mm in diameter and

650–800 grams in weight [8], [10]–[12]. Meanwhile, the jack used is 25–35 mm in diameter [12]. To score points in this Petanque game, the two competing teams are competing to try to throw the boule ball that each has to be thrown as close as possible to the jack ball that was thrown at the beginning of the game. In the rules made by the FFPJP [10], the meter is used as a measuring tool when there are points that are disputed or doubts about the boule distance to the jack in order to produce an objective value decision response. The meter and measurement methods used still apply conventional patterns, giving rise to errors that are prone to doubts about the results obtained, depending on the referee's role as judge and adjudicator. With conventional measurements and referees who witness them, it has the potential to influence the results of measurements that will be obtained based on factors of vision, physical health, mind, and fitness. Thus, it can produce measuring values that are less solid, concrete, and convincing because the understanding of how to read the meter is also different for each person, both due to factors of reading perspective and the visual abilities of different individual readers.

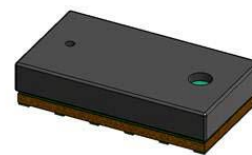

*Figure 1 Petanque Point Measurement*  
(source: [13])

Talking about measurement methods, in this case using conventional patterns in other fields, has been described as having various weaknesses that make them less effective in getting measurement results like is shown in figure 1. One example is that in measuring road and bridge construction using conventional measurement methods, there are drawbacks such as acquisition requiring quite a long time and a large number of personnel in the field and their mobilization, the potential for errors that affect the analysis, and poor accuracy due to low reference points. obtained slightly [14]. Therefore, the role of technology is the key to the solution, especially in this explanation regarding distance measurement in the petanque sport, so that more concrete measurement results are obtained. solid and convincing, and the measurement value can be accounted for in front of many people.

There is previous research that is relevant to this discussion; one of the studies from Safi et al. [15] concerns measuring the water level in ditch channels using ultrasonic sensors against a background of conventional measurements, which take a large amount of time and effort. Then, from the research of Molle et al. [16], they used a time-of-flight sensor as a water level meter in a solar-powered clean water pump system for the relocation of flood victims with inadequate electricity and clean water availability. Meanwhile, this study

used a time-of-flight sensor in the form of the VL53L0X as a measure of the distance between the boules and the jacks in the petanque sport. VL53L0X is one package distance sensor like is shown in figure 2. In a study by Luthfi et al. [17] regarding a rail fault detection system that also uses the VL53L0X sensor, the results obtained showed an error rate of around 2.37 mm to 4.12 mm. The VL53L0X has an error rate of up to 3% under the best conditions and 10% under less optimal conditions [18], and another study from Wijaya et al. [19] explained that the accuracy error rate ranges from 2.54% to 39.8%. With a measurement capability of up to 2 meters [19], the light source from the VL53L0X laser is invisible and very narrow, so there is no problem with linearity or accuracy [20]. The VL53L0X is included in the category of time-of-flight sensors that apply twice the sensor and object distance [21] with high-speed infrared and cannot be seen by human vision, so that distance measurements can be carried out accurately [22].



*Figure 2. VL53L0X Optical LGA12*  
(source: [23])

In managing the process of obtaining data from the VL53L0X sensor as input, a microcontroller is needed that also regulates the operation of the electronic devices connected to it. In addition, this microcontroller also has a program store. The microcontroller used is the Arduino Uno R3, which is an open-source microcontroller platform for the application and development of electronics for users with a combination of hardware and software capabilities. In short, Arduino, as the main component in managing this electronic circuit, according to Prabhu et al. [24], has the ability to read input data from sensors, which is then processed and realized based on this data on the actuator as output. Besides having hardware in the form of microcontrollers with various versions and features, Arduino also has an integrated development environment as programming development software that is compatible with Arduino microcontrollers using the C++ language.

It is important to apply the VL53L0X sensor, which is a time-of-flight sensor, to obtain accurate and precise distance measurement results for the petanque sport. The potential accuracy of the VL53L0X sensor distance can assist the referee in making decisions when faced with a difficult situation, such as awarding points to the Petanque team that is entitled to receive them. The VL53L0X technology in the application of measurements in the Petanque sport can also make players focus more on matches and game techniques so that they are not too affected mentally and emotionally by the results of measurements in awarding points that are technical measurements. Even though Petanque is still not popular and has only just entered Indonesia for the first time at the Sea Games in Palembang in 2011 [8], its potential to be widely recognized by Indonesians can grow even more. Therefore, the use of time-of-

flight sensor technology in the form of the VL53L0X is a substitute for a conventional meter in Petanque, which is used when there is a ball distance dispute that determines the Petanque match and minimizes the potential for conflict and even riots by Petanque supporters who watch as a result of the distance measurement dispute.

## II. METHOD

This study uses a quantitative approach to the formation of prototypes. The quantitative approach is based on obtaining the results of measuring the distance between the sensors directed at the boule ball, which is also compared with a conventional meter, and processing the values obtained to obtain an accuracy value and an error value. Comparisons were made to determine the level of accuracy of the tools and prototypes being tested. Prototype formation is carried out by forming an electronic circuit using the necessary components so that testing and data retrieval of distance measurement values can be carried out. There are stages of research carried out in the form of a diagram in Figure 3.

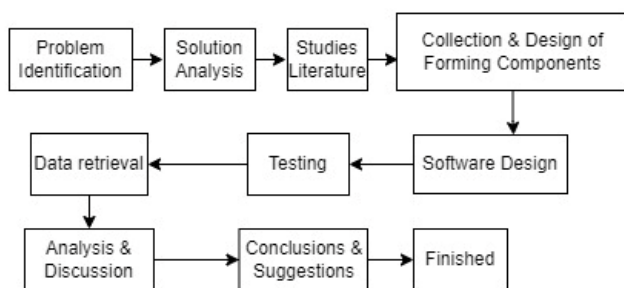

Figure 3. Research Stages

### Collection and Design of Forming Components

The components needed in the prototype formation in this study, some of which are the main components, are the VL53L0X sensor, Arduino Uno R3, KY-008 laser, and boule balls. Meanwhile, other forming components such as Arduino Uno serial cables and jumper cables, as well as computers and PCs that have the Arduino IDE installed,

Arduino is a microcontroller that is an important part of electronic circuit control devices and also acts as a store of control or controlling programs that will be implemented actuarially in accordance with the plans in the program. The microcontroller is the core component that becomes the brain of the planned implementation of a series in which there is a central processing unit (CPU). In addition, especially Arduino R3 like is shown in figure 4 has storage sections, peripherals, and controllers such as Random Access Memory (RAM), EEPROM/EPROM/PROM/ROM, I/O (input-output), Serial & Parallel, Timer, CPU, and Interrupt Controller [25]. Arduino Uno uses the ATmega 328 chipset packaged DIP (Dual In-Line Package) with 14 digital I/O pins and 6 analog I/O pins and operates at a working voltage input of 5–20 VDC and a maximum current of 40 mA [24], [26]–[28]. The programming is carried out on an IDE owned by Arduino itself called Arduino IDE, which functions to compile a structured coding program (source code) for the microcontroller IC that becomes the controller [29].

<https://doi.org/10.26740/inajeee.v6n2>



Figure 4. Arduino Uno R3 (sourcer: [27])

Time-of-Flight (ToF) is a method that combines sensors and objects by measuring distance by comparing microwave signals when sent or transmitted to the target object and when received, detecting the waves received without noise interference [16]. The essence of ToF refers to the speed of light (including infrared) and its technical principle, that is, the ToF emitter emits photons that are reflected by the target object, which are then detected by a SPAD (Single Photon Avalanche Diode) receiver where the difference between radiation and reception lies, giving the actual distance, which is very accurate in millimeters [23]. The ToF sensor can measure the absolute distance to the target object without affecting the reflection of the object, which also affects the measurement results [18]. One of them that has a ToF working principle is the VL53L0X sensor, which works at the recommended 2.8 VDC voltage. This sensor is a measurement and non-imaging type, can measure a maximum distance of 2 meters, and uses I2C serial communication for both serial (SDA) and serial clock (SCL) data using a laser beam with a laser emitting section using a VCSEL (Vertical Cavity Surface-Emitting Laser) device with a wavelength of 940 nm and is a class 1 laser that is completely invisible to the human eye [17], [19], [21]. The beam generated by VCSEL is then reflected by objects and received or detected by SPAD technology [23]. In this research, using VL53L0X was made by modul package like is shown in figure 5.



Figure 5. Modul VL53L0X (source: [23])

As a guide for the VL53L0X sensor with a beam that is not harsh on the eyes, the KY-008 laser plays a role in this. KY-008, which is a diode laser, or what can be called an optical laser, that can produce visible light and the physic of KY-008 like is shown in figure 6. This laser is highly compatible for non-contact measurement, which can make the whole measurement system powerful [32]. KY-008 as a transmitter has a wavelength of 650 nm at the receiving point and the ability of the beam to illuminate and hit objects up to 1 meter, making it quite suitable indoors [33]. Equipped with a red light, the wavelength is 635–700 nm, it operates on 5 V DC with a current consumption of 30 mA and a current consumption of 5 mW at operating temperatures from -10 °C to 40 °C, and it can be controlled by

the I/O pins in the microcontroller [34]–[36]. Manufactured by Keyes, KY-008 consists of a laser diode and resistor and has 3 pins, namely Vcc, signal out, and ground.



Figure 6. Laser KY-008  
(source: [35], [36])

Of the several main components that will form a hardware electronic circuit, each of them plays a role as input, process, and output like is shown in figure 7. VL53L0X as input for distance measurement data collection. KY-008 is also an input that only aims at the target object. Arduino Uno, which acts as a process and will later be connected to input, each of which will enter the I/O pin, which acts as input, with a working voltage of KY-008 and VL53L0X taken from this microcontroller at 5V. The Arduino I2C pin is attached to the SDA-SCL portion of the VL53L0X (ToF), and the signal out section of KY-008 is connected to the digital I/O pin. Then, for output, use the serial monitor on the Arduino IDE. There are several other components that form a complement to this study, such as jumper cables, which are used as connectivity between the sensor and the microcontroller. Flexible jumper cables, male-male or male-female, depending on needs.

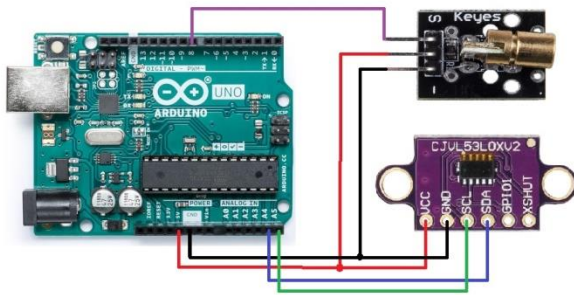

Figure 7. Hardware Network Design

### Software Design

In designing this software based on the flowchart shown in Figure 7, the laser and the ToF sensor are on, and their beam is directed at the target object. The beam direction will be adjusted based on the visible beam indicator of the laser's performance. The ToF sensor will identify the distance value in millimeters. The emission is carried out by the ToF sensor in a single shot and returns in millimeter readings, so it uses a library reference, namely `readRangeSingleMillimeters()`. Then, the measurement value in millimeters will be displayed in real-time on the serial monitor from the Arduino IDE.

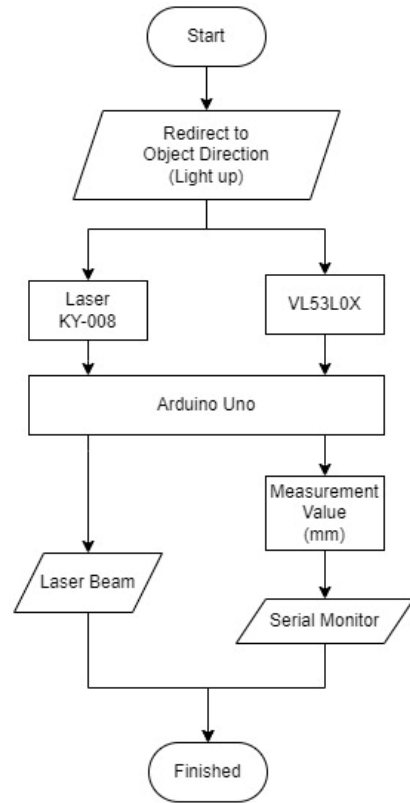

Figure 8. Program Design

### III. RESULTS AND DISCUSSION

The test was carried out with a prototype that works with a laser and a ToF sensor as input, which will direct the beam towards a boule ball as the target object. Performed with a minimum of 50 variations over a predetermined distance. This means that there will be 50 data values for distance measurements taken. In determining the distance based on a conventional meter as a comparison with the prototype. The difference in the value of the distance between successive data ranges from 1 cm.



Figure 9. Boule Ball Target Object Testing

The collected data will then be processed to find the accuracy value. The accuracy value is obtained by adapting to the calculation that was also carried out by Miftahuddin et al. [37], which is carried out by: determining the expected distance manually; comparing the distance between prototype and manual; calculating the error percentage (e); and calculating the percentage level of accuracy. In addition, an approach was made using the mean absolute deviation (MAD) and mean absolute percentage error (MAPE), which, according to Krisma et al. [38], both of these methods are used as an evaluation of the



absolute amount of error. MAD acts as an evaluation of the average, mean, or error of each error between the desired data and actual data, while MAPE acts as a measurement of error by calculating the percentage deviation between the desired data and actual data.

The data collection that has been done will be re-validated by looking for the standard deviation ( $\sigma$ ) as a good measure of the spread of data and how close the data collection is to the average of the difference between The level of deviation of each data point from the mean This means that the greater the standard deviation value, the more diverse the power values are and the less accurate they are with the mean, and vice versa. If the mean value is greater than the standard deviation value, it means that the data obtained is less varied but more accurate with the mean. And it can be said that the standard deviation is good. The calculation of the mean and standard deviation is, of course, inseparable from the amount of data collected (n). In this study, the calculation of the mean is included in the MAD, so it has a relationship with the standard deviation. According to Setiawan [39], the role of the standard deviation and MAD in this case is that the standard deviation is the variation in the distribution of the overall data, while the MAD is the difference in the mean data and absolute data. The MAPE approach has a measurable indicator as the accuracy of the test, as stated by Krisdianto et al. [40] with the interval and interpretation of the description as shown in the table 1.

Table 1. MAPE Interpretation

No.	MAPE Percentage	Interpretation
1.	$\leq 10\%$	Very accurate
2.	10% - 20%	Good
3.	20% - 50%	Fairly Good / Reasonable
4.	$> 50\%$	Not accurate

The stages of this research went through several stages to obtain an accuracy value with the following description:

- a. Manually determining the expected distance
 

It was carried out by experimenting with the help of a metering instrument as a comparison with the measurements made by the prototype.
- b. Comparison of distance between prototype and manual
 

This is done by obtaining the difference between the desired value and the actual value, and the difference value, or what is called the error value, is obtained. Then, the MAD approach is used to find out the difference between the mean error value and the absolute error value.
- c. Error percentage calculation ( $e$ )
 

Percentages are made at each measuring distance, which then, as a whole, obtain the MAPE results as the overall error value.
- d. Calculation of the percentage level of accuracy ( $a$ ).
 

Regarding the calculation of the error value, the overall accuracy value is obtained by dividing 100% by the overall error value.

Table 2. Accuracy of Measurement Results on Boule Objects

No.	$X_m$	$X_p$	$ X_p - X_m $	Lux	$e$
1.	17 mm	<b>10 mm</b>	7 mm	192,5 lx	70,00 %
2.	18 mm	<b>20 mm</b>	2 mm	180,83 lx	10,00 %
3.	29 mm	<b>30 mm</b>	1 mm	192,5 lx	3,33 %
4.	40 mm	<b>40 mm</b>	0 mm	191,67 lx	0,00 %
5.	53 mm	<b>50 mm</b>	3 mm	192,5 lx	6,00 %
6.	67 mm	<b>60 mm</b>	7 mm	192,5 lx	11,67 %
7.	79 mm	<b>70 mm</b>	9 mm	192,5 lx	12,86 %
8.	97 mm	<b>80 mm</b>	17 mm	192,5 lx	21,25 %
9.	127 mm	<b>90 mm</b>	37 mm	192,5 lx	41,11 %
10.	148 mm	<b>100 mm</b>	48 mm	192,5 lx	48,00 %
11.	183 mm	<b>110 mm</b>	73 mm	192,5 lx	66,36 %
12.	204 mm	<b>120 mm</b>	84 mm	193,33 lx	70,00 %
13.	212 mm	<b>130 mm</b>	82 mm	192,5 lx	63,08 %
14.	229 mm	<b>140 mm</b>	89 mm	192,5 lx	63,57 %
15.	192 mm	<b>150 mm</b>	42 mm	193,33 lx	28,00 %
16.	226 mm	<b>160 mm</b>	66 mm	192,5 lx	41,25 %
17.	317 mm	<b>170 mm</b>	147 mm	192,5 lx	86,47 %
18.	331 mm	<b>180 mm</b>	151 mm	192,5 lx	83,89 %
19.	335 mm	<b>190 mm</b>	145 mm	192,5 lx	76,32 %
20.	295 mm	<b>200 mm</b>	95 mm	192,5 lx	47,50 %
21.	316 mm	<b>210 mm</b>	106 mm	192,5 lx	50,48 %
22.	380 mm	<b>220 mm</b>	160 mm	191,67 lx	72,73 %
23.	383 mm	<b>230 mm</b>	153 mm	192,5 lx	66,52 %
24.	366 mm	<b>240 mm</b>	126 mm	193,33 lx	52,50 %
25.	371 mm	<b>250 mm</b>	121 mm	193,33 lx	48,40 %
26.	419 mm	<b>260 mm</b>	159 mm	193,33 lx	61,15 %
27.	427 mm	<b>270 mm</b>	157 mm	193,33 lx	58,15 %
28.	411 mm	<b>280 mm</b>	131 mm	193,33 lx	46,79 %
29.	435 mm	<b>290 mm</b>	145 mm	193,33 lx	50,00 %
30.	463 mm	<b>300 mm</b>	163 mm	193,33 lx	54,33 %
31.	387 mm	<b>310 mm</b>	77 mm	193,33 lx	24,84 %
32.	418 mm	<b>320 mm</b>	98 mm	193,33 lx	30,63 %
33.	425 mm	<b>330 mm</b>	95 mm	197,5 lx	28,79 %
34.	446 mm	<b>340 mm</b>	106 mm	198,33 lx	31,18 %
35.	445 mm	<b>350 mm</b>	95 mm	198,33 lx	27,14 %
36.	449 mm	<b>360 mm</b>	89 mm	198,33 lx	24,72 %
37.	496 mm	<b>370 mm</b>	126 mm	198,33 lx	34,05 %
38.	490 mm	<b>380 mm</b>	110 mm	199,17 lx	28,95 %
39.	509 mm	<b>390 mm</b>	19 mm	199,17 lx	4,87 %
40.	518 mm	<b>400 mm</b>	118 mm	199,17 lx	29,50 %
41.	535 mm	<b>410 mm</b>	125 mm	198,33 lx	30,49 %
42.	535 mm	<b>420 mm</b>	115 mm	199,17 lx	27,38 %
43.	550 mm	<b>430 mm</b>	120 mm	199,17 lx	27,91 %
44.	555 mm	<b>440 mm</b>	115 mm	199,17 lx	26,14 %
45.	558 mm	<b>450 mm</b>	108 mm	199,17 lx	24,00 %
46.	569 mm	<b>460 mm</b>	109 mm	198,33 lx	23,70 %
47.	570 mm	<b>470 mm</b>	100 mm	189,17 lx	21,28 %
48.	587 mm	<b>480 mm</b>	107 mm	188,33 lx	22,29 %
49.	575 mm	<b>490 mm</b>	85 mm	189,17 lx	17,35 %
50.	580 mm	<b>500 mm</b>	80 mm	189,17 lx	16,00 %

$$\text{error } (e) = \frac{|x_p - x_m|}{x_p} \times 100\% \quad (1)$$

$$\text{MAD} = \frac{\sum |x_m - x_p|}{n} \quad (2)$$

$$\text{accuracy } (a) = 100\% - e \quad (3)$$

$$\sigma = 1,25 \times \text{MAD} \quad (4)$$

$$\text{MAPE} = \sum_{t=1}^n \left| \frac{x_m - x_p}{x_p} \right| \times 100\% \quad (5)$$

The test was carried out using targets with a distance range of 1 cm to 50 cm. This distance is based on information obtained from the experience of competing Petanque athletes, to be precise, at the Petanque Student Activity Unit (UKM) at Surabaya State University (Unesa) regarding the use of meters in a Petanque competition. This test was carried out in a laboratory room with maximum lighting.



Figure 10. Testing with Beam-Shaped Object Targets

Therefore, it can be determined that the measurement of the VL53L0X sensor on the boule ball object produces a measurement value that is less accurate, has a large difference from the actual measurement value, and tends to be unstable. This is also done on other objects that also have curvature as targets, and the results are not much different. So, a second series of tests was carried out with the target using a flat space object, namely a cube shape.

From the first series of tests carried out 50 times like the results is shown in table 2 what did the test like shown in figure 9, the results obtained an accuracy of 61.74% with an average overall error value of 90.46 mm, an overall error value of 38.26%. standard deviation of 113.08 and a lighting intensity of 193.87 lx. This stage is testing with the object of this research, namely a boule ball, and the sensor is directly directed at the ball. The results obtained are values that are still very dynamic, fluctuating, changeable, and very random, and the total error value is still in a reasonable or good enough state, so it is considered inaccurate because the average error is quite high (up to 9 cm) for measurements in the Petanque game and needs to improve. It should be noted that this test also includes a smoothing filter in the coding program, which, according to Khairi [41], is useful for smoothing sensor readings, making it difficult to determine. By reading every 13 data lines on the Arduino IDE serial monitor, reading time is limited to 15 seconds.

Table 3. Accuracy of Measurement Results on Flat Plane Objects

No.	$X_m$	$X_p$	$ X_p - X_m $	Lux	$e$
1.	24 mm	<b>10 mm</b>	14 mm	198,33 lx	140,00 %
2.	25 mm	<b>20 mm</b>	5 mm	199,17 lx	25,00 %
3.	39 mm	<b>30 mm</b>	9 mm	199,17 lx	30,00 %
4.	42 mm	<b>40 mm</b>	2 mm	199,17 lx	5,00 %
5.	54 mm	<b>50 mm</b>	4 mm	199,17 lx	8,00 %
6.	65 mm	<b>60 mm</b>	5 mm	199,17 lx	8,33 %
7.	76 mm	<b>70 mm</b>	6 mm	199,17 lx	8,57 %
8.	86 mm	<b>80 mm</b>	6 mm	199,17 lx	7,50 %
9.	96 mm	<b>90 mm</b>	6 mm	194,17 lx	6,67 %
10.	106 mm	<b>100 mm</b>	6 mm	199,17 lx	6,00 %
11.	113 mm	<b>110 mm</b>	3 mm	197,5 lx	2,73 %
12.	123 mm	<b>120 mm</b>	3 mm	199,17 lx	2,50 %
13.	131 mm	<b>130 mm</b>	1 mm	199,17 lx	0,77 %
14.	143 mm	<b>140 mm</b>	3 mm	183,33 lx	2,14 %
15.	153 mm	<b>150 mm</b>	3 mm	199,17 lx	2,00 %
16.	166 mm	<b>160 mm</b>	6 mm	199,17 lx	3,75 %
17.	173 mm	<b>170 mm</b>	3 mm	200 lx	1,76 %
18.	182 mm	<b>180 mm</b>	2 mm	198,33 lx	1,11 %
19.	194 mm	<b>190 mm</b>	4 mm	199,17 lx	2,11 %
20.	207 mm	<b>200 mm</b>	7 mm	199,17 lx	3,50 %
21.	213 mm	<b>210 mm</b>	3 mm	200 lx	1,43 %
22.	223 mm	<b>220 mm</b>	3 mm	202,5 lx	1,36 %
23.	231 mm	<b>230 mm</b>	1 mm	200,83 lx	0,43 %
24.	243 mm	<b>240 mm</b>	3 mm	200,83 lx	1,25 %
25.	253 mm	<b>250 mm</b>	3 mm	201,67 lx	1,20 %
26.	262 mm	<b>260 mm</b>	2 mm	200,83 lx	0,77 %
27.	272 mm	<b>270 mm</b>	2 mm	201,67 lx	0,74 %
28.	283 mm	<b>280 mm</b>	3 mm	200,83 lx	1,07 %
29.	293 mm	<b>290 mm</b>	3 mm	200,83 lx	1,03 %
30.	304 mm	<b>300 mm</b>	4 mm	200,83 lx	1,33 %
31.	313 mm	<b>310 mm</b>	3 mm	200 lx	0,97 %
32.	325 mm	<b>320 mm</b>	5 mm	200,83 lx	1,56 %
33.	333 mm	<b>330 mm</b>	3 mm	200,83 lx	0,91 %
34.	342 mm	<b>340 mm</b>	2 mm	201,67 lx	0,59 %
35.	352 mm	<b>350 mm</b>	2 mm	200 lx	0,57 %
36.	361 mm	<b>360 mm</b>	1 mm	200,83 lx	0,28 %
37.	373 mm	<b>370 mm</b>	3 mm	200,83 lx	0,81 %
38.	383 mm	<b>380 mm</b>	3 mm	200,83 lx	0,79 %
39.	399 mm	<b>390 mm</b>	9 mm	195 lx	2,31 %
40.	403 mm	<b>400 mm</b>	3 mm	199,17 lx	0,75 %
41.	418 mm	<b>410 mm</b>	8 mm	119,17 lx	1,95 %
42.	427 mm	<b>420 mm</b>	7 mm	200 lx	1,67 %
43.	435 mm	<b>430 mm</b>	5 mm	200 lx	1,16 %
44.	446 mm	<b>440 mm</b>	6 mm	198,33 lx	1,36 %
45.	457 mm	<b>450 mm</b>	7 mm	198,33 lx	1,56 %
46.	468 mm	<b>460 mm</b>	8 mm	197,5 lx	1,74 %
47.	477 mm	<b>470 mm</b>	7 mm	199,17 lx	1,49 %
48.	483 mm	<b>480 mm</b>	3 mm	199,17 lx	0,63 %
49.	498 mm	<b>490 mm</b>	8 mm	197,5 lx	1,63 %
50.	503 mm	<b>500 mm</b>	3 mm	198,33 lx	0,60 %

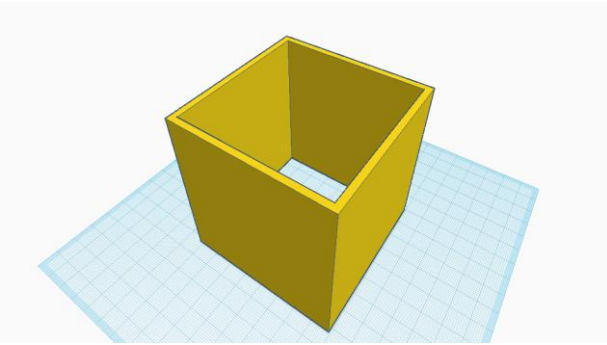

Figure 11. Boule Auxiliary Design



Figure 12. Testing with Boule Balls and Flat Plane Tools

From the second series of tests like the results is shown in table 3 what did the test like shown in figure 10, which were carried out 50 times, the results obtained an accuracy of 93.97% with an average overall error value of 4.42 mm, an overall error value of 6.03%, and a standard deviation of 5.53. However, the 1 cm measurement obtained an inaccurate error value of 140%, and the 2 cm and 3 cm measurements obtained an error value of > 20%, which means it is quite good or reasonable. From these provisions, additional results are provided as follows:

- a. If the prototype is considered inaccurate at 1 cm measurement, data is obtained from 49 trials, which produce accuracy reaching 96.71% with an average overall error value of 4.22 mm, an overall error value of 3.29%, and a standard deviation of 5.28.
- b. If the prototype is considered inaccurate in measuring 1 cm to 3 cm, data is obtained from 47 trials, which produce accuracy reaching 97.74% with an average overall error value of 4.11 mm, an overall error value of 2.26 percent, and a standard deviation of 5.13.

The light intensity in this test is 197.57 lx.

From these results, the third series of tests was continued according to the object of this study, namely boule balls, with the help of a flat plane what did the test like shown in figure 12, with the expected results being more stable and in accordance with the actual measurement results. From the two previous test models for measuring the distance to the ball using the VL53L0X sensor, a tool is needed to obtain more optimal, stable, and in accordance with the actual measuring results of the boule ball distance. Then a cube-shaped tool is formed with a size that contains the diameter of the boule ball, which is 7 cm. So, the inner size of the cube is 75 mm by 75 mm, with a thickness of 3 mm. Thus, in the sensor source code, the reading will be reduced by 3 mm for a more appropriate reading.

Table 4. Accuracy of Measurement Results on Boule Objects and Flat Plane Tools

No.	$X_m$	$X_p$	$ X_p - X_m $	Lux	$e$
1.	18 mm	<b>10 mm</b>	8 mm	189,17 lx	80,00 %
2.	21 mm	<b>20 mm</b>	1 mm	189,17 lx	5,00 %
3.	33 mm	<b>30 mm</b>	3 mm	198,33 lx	10,00 %
4.	37 mm	<b>40 mm</b>	3 mm	182,5 lx	7,50 %
5.	52 mm	<b>50 mm</b>	2 mm	190,83 lx	4,00 %
6.	61 mm	<b>60 mm</b>	1 mm	182,5 lx	1,67 %
7.	72 mm	<b>70 mm</b>	2 mm	197,5 lx	2,86 %
8.	83 mm	<b>80 mm</b>	3 mm	187,5 lx	3,75 %
9.	92 mm	<b>90 mm</b>	2 mm	198,33 lx	2,22 %
10.	102 mm	<b>100 mm</b>	2 mm	174,17 lx	2,00 %
11.	110 mm	<b>110 mm</b>	0 mm	185 lx	0,00 %
12.	118 mm	<b>120 mm</b>	2 mm	189,17 lx	1,67 %
13.	129 mm	<b>130 mm</b>	1 mm	173,33 lx	0,77 %
14.	136 mm	<b>140 mm</b>	4 mm	200 lx	2,86 %
15.	146 mm	<b>150 mm</b>	4 mm	198,33 lx	2,67 %
16.	157 mm	<b>160 mm</b>	3 mm	199,17 lx	1,88 %
17.	167 mm	<b>170 mm</b>	3 mm	197,5 lx	1,76 %
18.	177 mm	<b>180 mm</b>	3 mm	194,17 lx	1,67 %
19.	187 mm	<b>190 mm</b>	3 mm	197,5 lx	1,58 %
20.	203 mm	<b>200 mm</b>	3 mm	183,33 lx	1,50 %
21.	207 mm	<b>210 mm</b>	3 mm	199,17 lx	1,43 %
22.	220 mm	<b>220 mm</b>	0 mm	195 lx	0,00 %
23.	229 mm	<b>230 mm</b>	1 mm	198,83 lx	0,43 %
24.	240 mm	<b>240 mm</b>	0 mm	196,67 lx	0,00 %
25.	250 mm	<b>250 mm</b>	0 mm	200 lx	0,00 %
26.	260 mm	<b>260 mm</b>	0 mm	191,67 lx	0,00 %
27.	271 mm	<b>270 mm</b>	1 mm	191,67 lx	0,37 %
28.	281 mm	<b>280 mm</b>	1 mm	191,67 lx	0,36 %
29.	292 mm	<b>290 mm</b>	2 mm	192,5 lx	0,69 %
30.	304 mm	<b>300 mm</b>	4 mm	191,67 lx	1,33 %
31.	314 mm	<b>310 mm</b>	4 mm	192,5 lx	1,29 %
32.	324 mm	<b>320 mm</b>	4 mm	192,5 lx	1,25 %
33.	332 mm	<b>330 mm</b>	2 mm	192,5 lx	0,61 %
34.	342 mm	<b>340 mm</b>	2 mm	192,5 lx	0,59 %
35.	352 mm	<b>350 mm</b>	2 mm	192,5 lx	0,57 %
36.	365 mm	<b>360 mm</b>	5 mm	192,5 lx	1,39 %
37.	376 mm	<b>370 mm</b>	6 mm	192,5 lx	1,62 %
38.	383 mm	<b>380 mm</b>	3 mm	192,5 lx	0,79 %
39.	397 mm	<b>390 mm</b>	7 mm	192,5 lx	1,79 %
40.	408 mm	<b>400 mm</b>	8 mm	192,5 lx	2,00 %
41.	415 mm	<b>410 mm</b>	5 mm	192,5 lx	1,22 %
42.	424 mm	<b>420 mm</b>	4 mm	192,5 lx	0,95 %
43.	429 mm	<b>430 mm</b>	1 mm	193,33 lx	0,23 %
44.	441 mm	<b>440 mm</b>	1 mm	193,33 lx	0,23%
45.	450 mm	<b>450 mm</b>	0 mm	193,33 lx	0,00 %
46.	462 mm	<b>460 mm</b>	2 mm	193,33 lx	0,43 %
47.	471 mm	<b>470 mm</b>	1 mm	194,17 lx	0,21%
48.	480 mm	<b>480 mm</b>	0 mm	193,33 lx	0,00 %
49.	487 mm	<b>490 mm</b>	3 mm	193,33 lx	0,61 %
50.	501 mm	<b>500 mm</b>	1 mm	193,33 lx	0,20 %

From the third series of tests carried out 50 times like the results is shown in table 4, the results obtained an accuracy of 96.88% with an average overall error value of 2.52 mm, an

overall error value of 3.12%, and a standard deviation of 3.15. However, at 1 cm measurement, an inaccurate error value of 80% is obtained. From these provisions, additional results are provided as follows: If the prototype is considered inaccurate at 1 cm measurement, data is obtained from 49 trials, which produce an accuracy of 98.45% with an average overall error value of 2.41 mm, an overall error value of 1.55%, and a standard deviation of 3.01. This test was enclosed the boules auxiliary like shown in figure 11.

This test with a lighting intensity of 192.28 lx uses a different smoothing setting, namely by taking data every 25 seconds and having a time limit of 37 seconds. This was done because in this test, with the previous smoothing settings, random data was returned with a greater difference in error than in the second series of tests.

Overall, in this test, several adjustments are included in the source code regarding smoothing, which functions to make the reading of the resulting measurement values more stable. Because distances are measured by the VL53L0X without smoothing, the results obtained are very dynamic in changing the values obtained. In addition, to make the measurement results easier to read, they are subject to a delay of 1 second, or 1000 ms per data point, and use high accuracy mode with a timing budget of 200 ms.

#### IV. CONCLUSION

The research that has been carried out has yielded several results. Several series of tests were carried out on the basis of the first series of tests with a direct object on a boules ball, which obtained results that were very dynamic, fluctuating, changeable, very random, and less accurate (fair or good enough). Error = 38.26%.

Until it increased in the second series of tests using flat space objects with very accurate results (error = 2.26%) and measurement accuracy that is not recommended at a distance of 1 cm–3 cm,

Then, it increased again in the third series of tests using a boules ball object with a flat plane. In this test, the walking measurement is very accurate (error = 1.55%), with an accuracy measurement that is not recommended at a distance of 1 cm.

The standard deviation in the first test is 113.08; the second test is 5.13 with measurements at a distance of 1 cm–3 cm, which is not recommended; and the third test is 3.01 with measurements at a distance of 1 cm, which is not recommended. From this comparison, the measurement in the third test is the most accurate measurement. It is also directly proportional to the overall average error in each series of tests.

The VL53L0X sensor has great potential as one of the building components to replace conventional measuring instruments, thus helping parties involved in the boules sport have a more sporty match with the development of this measuring instrument technology.

The author feels that this research is still far from being perfect, so there are still a number of things that need to be developed and perfected for future researchers who are interested in similar topics and who are expected to obtain better and more improved results from this research.

<https://doi.org/10.26740/inajeee.v6n2>

- a. Requires an adjustment to the design of the measuring instrument using the VL53L0X sensor with adjustments to the test.
- b. It can be improved with other configurations of similar smoothing filters that are included in the source code to further refine sensor readings and improve more accurate readings.
- c. It needs consideration and adjustments before being tested outdoors, with the lighting intensity also being adjusted.

#### V. ACKNOWLEDGE

The author expresses his deepest gratitude to the Faculty of Engineering, Surabaya State University, especially the Microprocessor Laboratory, which has provided this research facility. The author also expresses his greatest gratitude to UKM Petanque Unesa, who is willing to support this research, especially in terms of the facilities and logistics of Petanque ball equipment.

#### REFERENCES

- [1] Rianto, H. Mubarak, and Aradea, "Pelatihan Penerapan Sistem Layanan Administrasi Penduduk Desa Berbasis Teknologi Informasi," *J. Pengabd. Siliwangi*, vol. 5, no. 1, pp. 68–72, 2019.
- [2] M. R. Simamora and J. W. Hasugian, "Penanaman Nilai-Nilai Kristiani bagi Ketahanan Keluarga di Era Disrupsi," *Regula Fidei*, vol. 5, no. 1, pp. 13–24, 2020.
- [3] I. K. Yoda, "Peran Olahraga Dalam Membangun Sdm Unggul Diera 4.0," *Ika*, vol. 18, no. 1, pp. 1–22, 2020.
- [4] F. A. Salam, I. P. A. D. Hita, and M. A. Juliansyah, "Aksiologi Penggunaan VAR Dalam Industri Olahraga," *J. Penjakora*, vol. 8, no. 2, p. 106, 2021, doi: 10.23887/penjakora.v8i2.32171.
- [5] A. Malik, S. Sunardi, and D. T. Ardianto, "Pengembangan Panduan Identifikasi Bakat Olahraga Berbasis Teknologi Sport Search," *J. Curric. Indones.*, vol. 3, no. 2, p. 54, 2020, doi: 10.46680/jci.v3i2.30.
- [6] E. B. Satriyo, "Perancangan pusat pelatihan atlet olah raga bulu tangkis di Malang dengan pendekatan smart building," Universitas Islam Negeri Maulana Malik Ibrahim Malang, 2020. [Online]. Available:
- [7] O. J. Setyawan, R. A. Permana, and D. A. Izzuddin, "Sosialisasi Olahraga Petanque Pada Masyarakat Di Komplek Gor Sasana Adhi Karsa Brebes," *J. Masy. Mengabdikan Nusant.*, vol. 1, no. 3, pp. 10–14, 2022, [Online]. Available:
- [8] A. O. Bustomi, T. Hidayah, A. Okilanda, and D. D. Putra, "Analisis gerak pointing pada olahraga petanque," *J. Sport Area*, vol. 5, pp. 65–75, 2020.
- [9] R. E. Cahyono and Nurkholis, "Analisis backswing dan release shooting carreau jarak 7 meter olahraga petanque pada atlet jawa timur," *J. Prestasi Olahraga*, vol. 1, no. 1, pp. 1–5, 2018, [Online]. Available:
- [10] FFPJP, "Le matériel," *ffpjp.org*. [Online]. (accessed Jan. 20, 2023).
- [11] J. D. Paulina and F. A. Irawan, "Analisis Kesesuaian Gerak Pointing dengan Posisi Jongkok pada Olahraga Petanque," *JOSSAE (Journal Sport Sci. Educ.*, vol. 7, no. 2021, pp. 17–23, 2022, [Online]. Available:
- [12] A. Wijaya, A. Rozak, M. Gunawan, H. Basri, and H. Chaniago, "Webinar pengenalan olahraga petanque bagi guru PJOK Sekolah," *MADDANA J. Pengabd. Kpd. Masy.*, vol. 1, no. 2, pp. 37–42, 2021.
- [13] Boulipédia, "Mesure de points à la pétanque," *boulipedia.com*, 2022. [Online]. (accessed Jan. 23, 2023).
- [14] S. R. Hadi and Direktorat Jenderal Bina Marga, "Pemanfaatan Teknologi 3D Terrestrial Laser Scanning Dalam Mendukung Konstruksi Jalan dan Jembatan," *binamarga.pu.go.id*, 2020. [Online]. (accessed Jan. 20, 2023).
- [15] M. Safi, I. Rosita, W. H. Pamungkas, Y. D. Atma, N. Bin Idris, and A. Daffa, "Monitoring Ketinggian Permukaan Air Menggunakan Telegram Bot Berbasis Nodemcu ESP8266," *METIK J.*, vol. 6, no. 2, pp. 123–132, 2022, doi: 10.47002/metik.v6i2.384.
- [16] W. H. S. Molle *et al.*, "Rancang Bangun Sistem Kendali Pompa Air Bersih Bertenaga Surya Di Kawasan Relokasi Korban Banjir Pandu," *J. Tek. Inform.*, vol. 15, no. 2, 2020, [Online]. Available:
- [17] K. M. Luthfi, F. Y. Suratman, and M. Ramdhani, "Sistem Deteksi Rel Patah Menggunakan Laser," in *e-Proceeding of Engineering*, 2021, vol. 8, no. 2, pp. 1021–1028.



- [18] N. R. Alfino and A. Aswardi, "Rancang Bangun Alat Pemotong Kentang Berbentuk Stick Berbasis Mikrokontroler ATmega 328," *JTEV (Jurnal Tek. Elektro dan Vokasional)*, vol. 6, no. 2, p. 8, 2020, doi: 10.24036/jtev.v6i2.108023.
- [19] A. P. Wijaya, N. Tamami, and H. Oktavianto, "Surface 3D Scanner Using Time of Flight Ranging Sensor with Cylindrical Coordinate System," *J. Mech. Eng. Mechatronics*, vol. 7, no. 1, pp. 35–50, 2022, [Online]. Available:
- [20] Adafruit, "Adafruit VL53L0X Time of Flight Distance Sensor," *Adafruit Industries*. [Online]. (accessed Jan. 22, 2023).
- [21] A. R. Zain, H. Mukhtar, Y. N. Wijayanto, U. Telkom, and S. Lidar, "Rancang Bangun Pemindai 3 Dimensi Resolusi Tinggi Pada Objek Jarak Menggunakan Lidar Design And Build High Resolution 3d Scanner On Near Object Using," in *eProceedings of Engineering*, 2021, vol. 8, no. 5, pp. 4504–4511. [Online]. Available:
- [22] Y. Wibisono, B. Setiawan, N. Sulistiyono, and D. A. Aziz, "Design And Development Of Tank / Volume Level Automation System Using Tof ( Time Of Flight ) Sensor Based On Arduino," *J. Marit. Malahayati*, vol. 3, no. 1, pp. 21–24, 2022, [Online]. Available:
- [23] STMicroelectronics, "Time of Flight (ToF) Sensors - FlightSense," *STMicroelectronics*, 2016. [Online] (accessed Jan. 21, 2023).
- [24] V. S. Prabhu, R. M. Abinaya, G. Archana, and R. Aishwarya, "IoT-based automatic library management robot," *Adv. Intell. Syst. Comput.*, vol. 1163, pp. 567–575, 2021, doi: 10.1007/978-981-15-5029-4\_46.
- [25] L. Raufun and S. Ardiasyah, "Prototype Pengontrol Pengisian Tandon Air Secara Paralel Menggunakan Solenoid Valve Berbasis Atmega 2560," *Informatika*, vol. 7, no. 2, pp. 30–35, 2018, [Online]. Available:
- [26] A. B. Pulungan and D. S. Goci, "Penggunaan Sistem Data logger Dalam Pencatatan Data Parameter Panel Surya berbasis Mikrokontroler," *JTEV (Jurnal Tek. Elektro dan ...)*, vol. 7, no. 2, pp. 337–344, 2021.
- [27] Arduino, "Arduino ® UNO R3 Target areas : Arduino ® UNO R3 Features," 2022
- [28] R. Iailathul Isra and R. Mukhaiyar, "Monitoring Kecepatan Angin Berbasis Mikrokontroler dan IoT," *JTEIN J. Tek. Elektro Indones.*, vol. 3, no. 2, pp. 437–447, 2022.
- [29] S. Aminah, H. Hambali, and R. F. Lubis, "Perancangan Alat Absensi Mahasiswa Berdasarkan Mata Kuliah Menggunakan E-KTP Berbasis NODEMCU," *JUTSI (Jurnal Teknol. dan Sist. Informasi)*, vol. 1, no. 1, pp. 103–110, 2021, doi: 10.33330/jutsi.v1i1.1054.
- [30] simon, "UNO R3 | Arduino Documentation | Arduino Documentation," *Arduino.Cc.* p. 4, 2022. [Online]. Available:
- [31] STMicroelectronics, "VL53L0X World smallest Time-of-Flight ranging and gesture detection sensor (Datasheet)," 2016
- [32] J. Venkatraman, R. Manwar, and K. M. Avanaki, "Development of a punch-o-meter for sport karate training," *Electron.*, vol. 8, no. 7, 2019, doi: 10.3390/electronics8070782.
- [33] D. H. Hareva, A. Wirawan, and B. y Hardjono, "Optimalisasi Penggunaan Pendingin Ruang Sistem Kelas Cerdas," in *Prosiding SISFOTEK*, 2020, pp. 1–6. [Online]. Available:
- [34] N. Cameron, *Electronics Projects with the ESP8266 and ESP32*. 2021. doi: 10.1007/978-1-4842-6336-5.
- [35] D. Bambang and M. N. Jaya, "Inovasi Perancangan Alat Klinometer Digital Pengukur Sudut Papi ( Precision Approach Path Indicator ) Di Bandara Internasional Adisutjipto Yogyakarta Innovation Design of Digital Clinometer Papi ( Precisio," *J. Tek. dan Keselam. Transp.*, vol. 3, no. 1, pp. 86–94, 2020.
- [36] M. R. Madani *et al.*, "Perancangan Perangkat Keras Target Penilaian Berbasis Laser Spot (Scoring Target Hardware Design Based On Laser Spot)," vol. 9, no. 3, pp. 1200–1205, 2022, [Online]. Available:
- [37] Y. Miftahuddin, S. Umaroh, and F. R. Karim, "Perbandingan Metode Perhitungan Jarak Euclidean, Haversine, Dan Manhattan Dalam Penentuan Posisi Karyawan," *J. Tekno Insentif*, vol. 14, no. 2, pp. 69–77, 2020, doi: 10.36787/jti.v14i2.270.
- [38] A. Krisma, M. Azhari, and P. P. Widagdo, "Perbandingan Metode Double Exponential Smoothing Dan Triple Exponential Smoothing Dalam Parameter Tingkat Error Mean Absolute Percentage Error (MAPE) dan Means Absolute Deviation (MAD) Alviani Krisma Putut Pamilih Widagdo Kata kunci-forecasting, Double Ex," *Pros. Semin. Nas. Ilmu Komput. dan Teknol. Inf.*, vol. 4, no. 2, pp. 81–87, 2019.
- [39] S. R. Setiawan, "Analisis Penerapan Standar Deviasi Dalam Penentuan Persediaan Pengaman Pada Ud Mirama Kota Gorontalo," *Gorontalo Manag. Res.*, vol. 1, no. 1, pp. 103–116, 2018.
- [40] A. H. Krisdianto, Rais, N. Fiskia, and H. Sain, "Prediksi Tingkat Produksi Padi di Sulawesi Tengah Menggunakan Analisis Algoritma FBprophet," *J. Ilm. Mat. Dan Terap.*, vol. 19, no. 2, pp. 2014–214, 2022, doi: 10.22487/2540766x.2022.v19.i2.16062.
- [41] M. H. Al Khairi, "Cara Memperhalus Pembacaan Sensor Pada Arduino Menggunakan Program Smoothing - Mahir Elektro," *Mahir Elektro*, 2022. [Online]. (accessed May 21, 2023).